

Scope

This document outlines matters to be considered when designing a product embodying a gigaNOVA® Reflexus A10315, Calvus A10340 and Flavus B5812-xx cellular antennas. These include recommendations about selecting a suitable location for the antenna, designing the matching circuit and the RF feed between the antenna and the radio chip, and integrating the antenna with other circuits required to support the radio chip. Advice is provided on the measurement techniques and instrumentation to carry out all the design steps; this should help users to establish whether they can carry out the integration in-house or should contact Antenova to make use of our integration service.

1. Introduction

gigaNOVA cellular antennas are mostly electrically very small – their longest dimension is much shorter than a quarter wavelength at the operating frequency. For many applications the antenna is mounted on a small printed circuit board, often in close proximity to other components or circuit boards, and with a variety of different connection methods. As a result the input impedance of the antenna is very dependent on the configuration within which it is used. This situation is not special to gigaNOVA antennas, but is a natural consequence of using antennas in these circumstances.

To provide the best results in any particular application, the designer needs to have some understanding of the possible effects of the configuration on RF performance. Once the configuration is established the performance of the antenna can be optimised by measuring its input impedance in situ, and designing an appropriate matching network so the RF chip is operating into a 50-ohm load impedance.

2. Selecting and placing an antenna

For applications in the cellular bands, the gigaNOVA product range provides a few alternative antennas. The first task is to select the right antenna for the application and to site the antenna on its associated module.

The antennas are mounted in an area clear of copper groundplane area of the PCB. These antennas generate electromagnetic fields of similar intensity on both sides of the PCB on which they are mounted. They will provide excellent results for applications in which the local fields created by the antenna will be clear of other circuit boards, metallic objects or interconnecting cables.

3. Antenna position

Unless prevented by special considerations the antenna should be placed on the edge of a PCB, where it will have a 'view' out of the equipment in which it is installed. If the PCB is small it is generally preferable to site the antenna along one of the short edges of the board, as this position will generally produce a larger impedance bandwidth than when the antenna is on the long edge.

A small clearance is required between the antenna and other components on both sides of the board, but if the components are only of low height (small SMD R, L or C), the clearance can be only 2mm. Higher components or components belonging to circuits which could interact with strong RF fields should be kept further away, with a clearance up to 5-10mm. A reasonable rule of thumb for components not sensitive to RF fields and not radiating RF noise is that they should lie below the line shown in Fig 1.

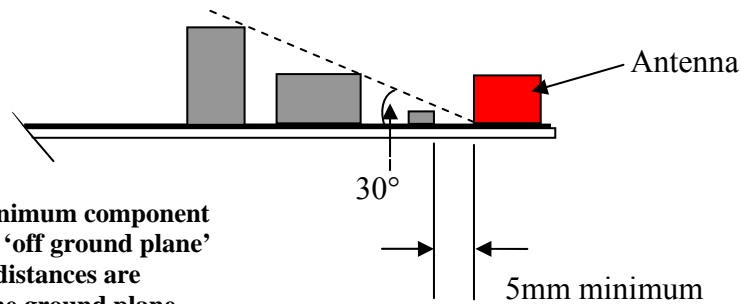

Fig 1: Typical minimum component clearances to the 'off ground plane' antenna, but the distances are measured from the ground plane edge.

The effect of infringing the suggested limit will be a progressive reduction of the impedance bandwidth of the antenna and an increased risk of loss of RF energy by coupling into other circuits. It is very difficult to provide hard quantitative guidelines because of interactions between the antenna, the PCB dimensions and the particular layout, component types and circuit functions of the relevant components. Detailed electromagnetic modelling is possible, but it is very expensive to model a complex circuit in the necessary detail, especially when some of the interactions involve complex digital ICs.

Numerous things can go wrong with an antenna design. The following list provides a few do's and don'ts which may serve as a good checklist in a final design. Many of these items seem obvious to the experienced antenna designer, but many of these issues are routinely encountered in practice.

- Never place ground plane or tracks underneath the antenna
- Never place the antenna very close to metallic objects
- In the final product, ensure that the wiring and components do not get too close to the antenna
- A monopole antenna such as Reflexus and Calvus will need a reasonable ground plane area to be efficient
- Do the final tuning in the end product enclosure, not in open air
- Never install an antenna in a vastly different layout than the reference design and expect it to work without tuning
- Do not use a metallic enclosure or metalized plastic for the antenna
- Test the plastic casing for high RF losses, preferably before production
- Never use low-Q loading components, or change manufacturer without retesting
- Do not use very narrow PCB tracks. The tracks should be relatively wide as space allows

4. Integration notes for the Reflexus A10315 Penta-band Antenna

4.1. Reflexus Antenna Placement

Fig 2 shows recommended placement for Reflexus relative to the ground plane.

Note: That the antenna feed and ground positions change depending if the antenna is placed on the LHS and the ground plane extends to the right of the antenna or on the RHS of the PCB and the ground plane extends to the left of the antenna. (Fig. 2)

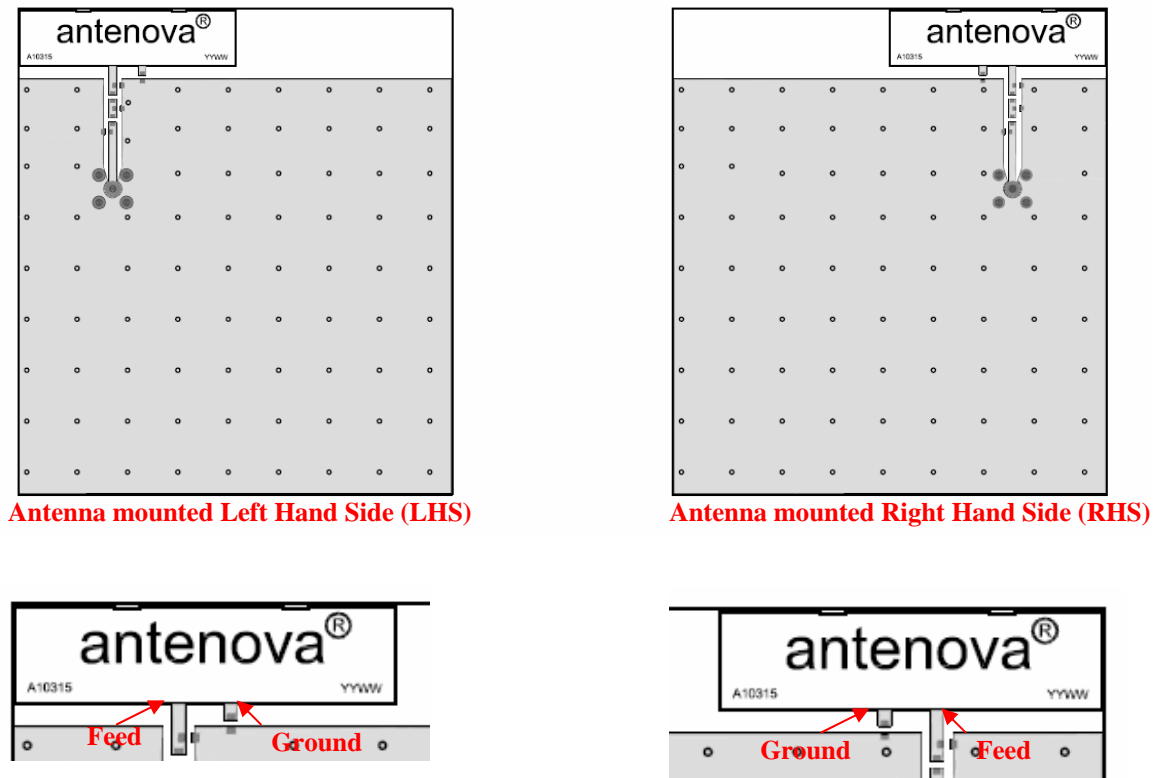
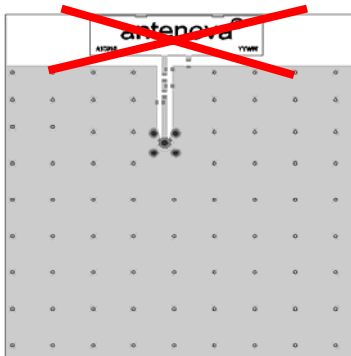

Fig 2: Antenna Placement and relative feed and ground positions

The following configuration should be avoided as it may result in sub-optimal performance.



4.2. Effect of ground plane to the side of Reflexus

For best performance no ground should be placed in the same area as the antenna as shown. The effect of having ground plane next to the antenna can be seen, the ground must be placed on the same side as the ground antenna connection (Fig. 3)

The reduced performance was tested on a reference board with 100mm long ground plane. The performance degradation may be increased on PCB's of different sizes.

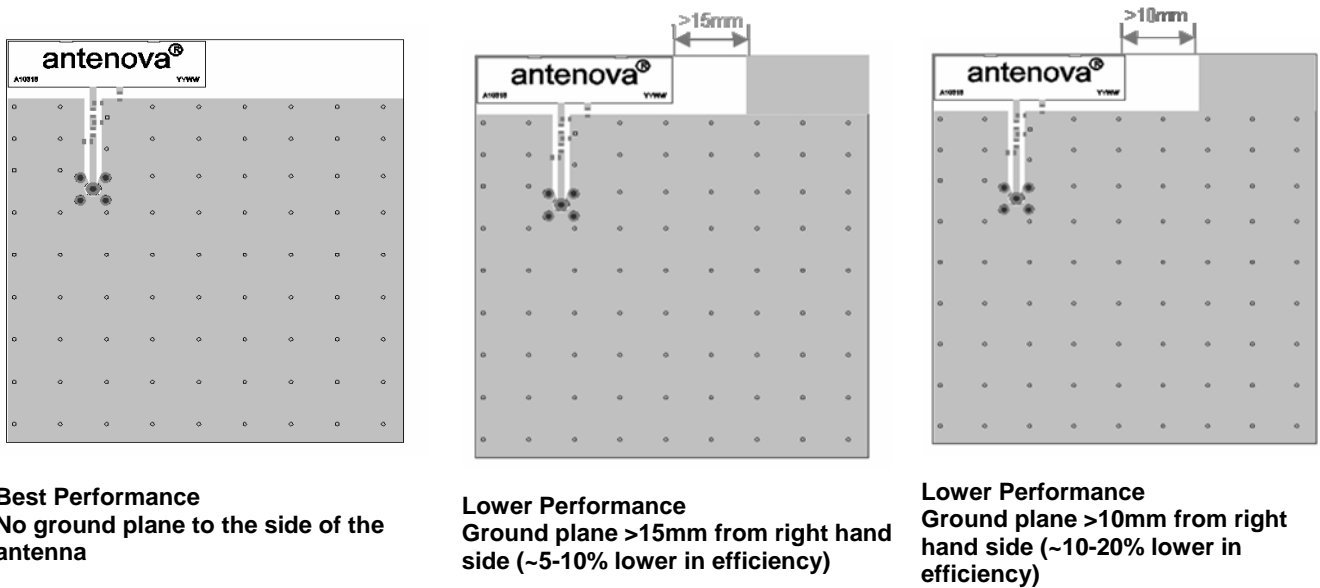
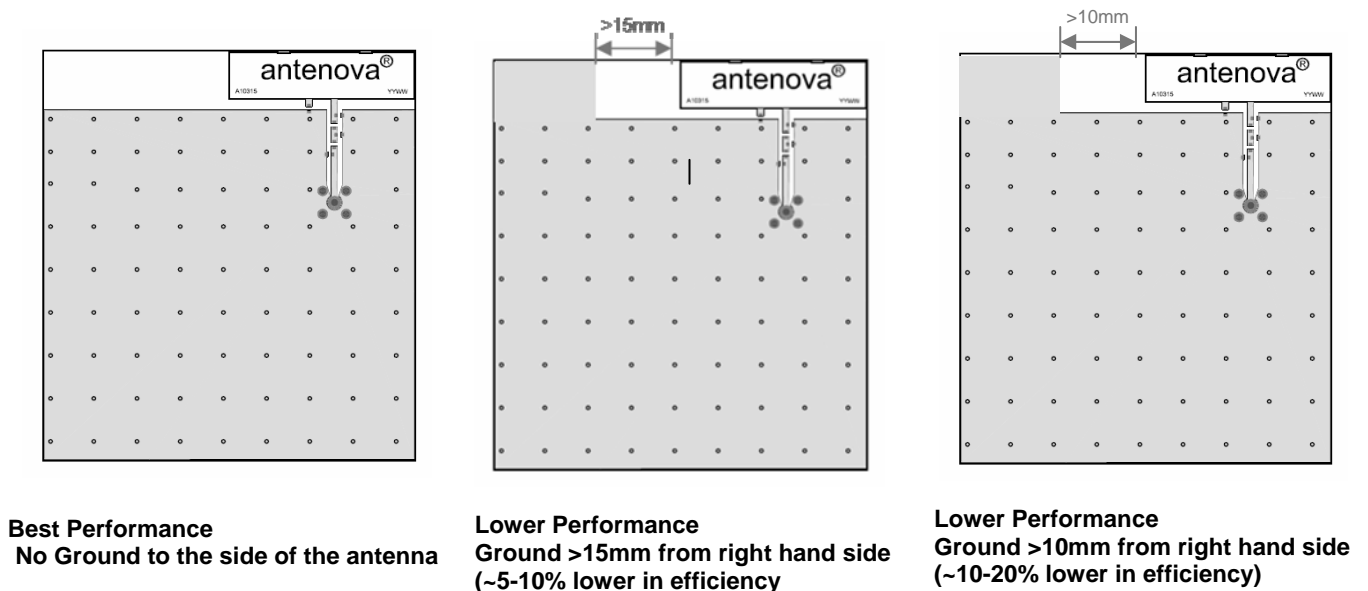

Fig 3. (Reflexus Ground Plane Positions)



In some circumstances Reflexus can also work with the ground plane as close as 5mm, for further technical advice please contact info@antenova for getting the best results from Reflexus into your product.

4.3. Performance Variation with Ground Plane Length

The test data below shows the affect of different ground plane lengths on the antenna in terms of antenna efficiency on all the GSM and WCDMA Bands. Fig. 4 shows the low-band and high-band performance variations.



Performance variation vs Gnd Plane Length (GSM850, GSM900)

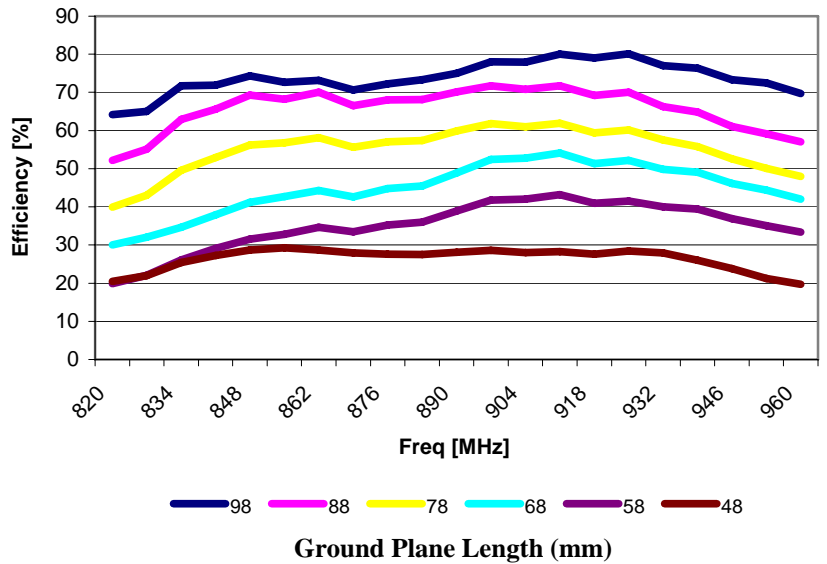
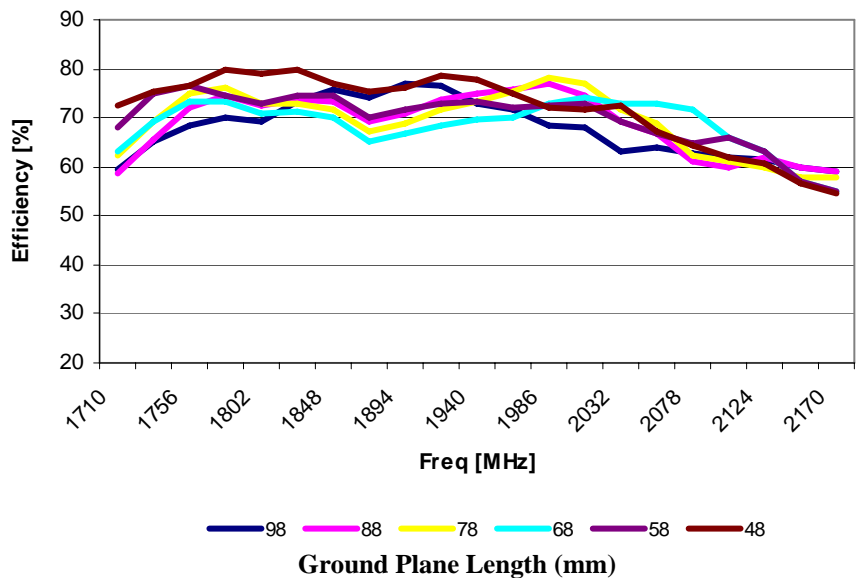

Fig. 4 – Antenna Efficiency Variation (Low-band (above graph), High-band (below graph))

Performance variation vs Gnd Plane Length (DCS, PCS and WCDMA)



5. Integration notes for the Calvus and Flavus Penta-band Antennas

5.1. Calvus and Flavus Antenna Placement

Fig 5 shows recommended placement options for Calvus relative to the ground plane.

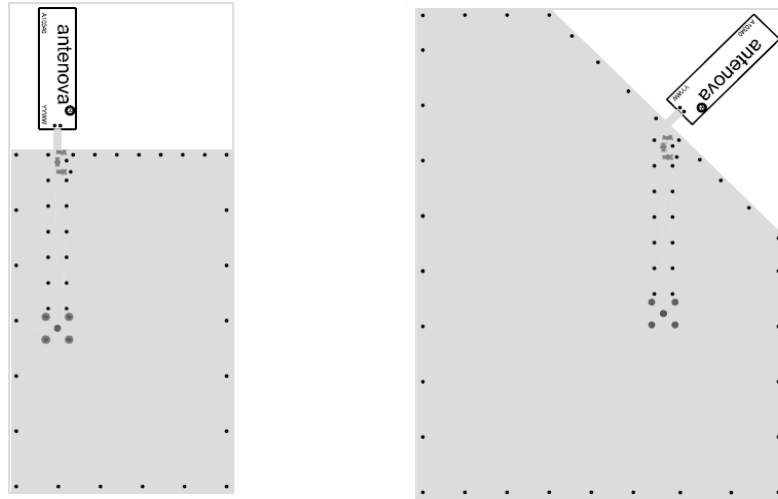

Fig. 5 – (Calvus and Flavus Vertical Placement)

5.2. Space saving configuration

Where board space is limited, Calvus can be positioned closer to the main PCB ground plane as shown below in Fig 6. In this position good results can be achieved in up to three bands, however, if all five bands are required, this configuration is not recommended.



Fig. 6 – (Calvus and Flavus Space-Saving Placement)

5.3. Effect of Ground Plane to the side of Calvus and Flavus

For best performance no ground should be placed in the same area as the antenna as shown. The effect of having ground plane next to the antenna (Fig 7.) can be seen. These guidelines also apply to the antenna being placed on the RHS of the PCB and the ground plane added to the LHS of the antenna

The reduced performance was tested on a reference board with 80mm long ground plane. The performance degradation may be increased on PCB's of different sizes.

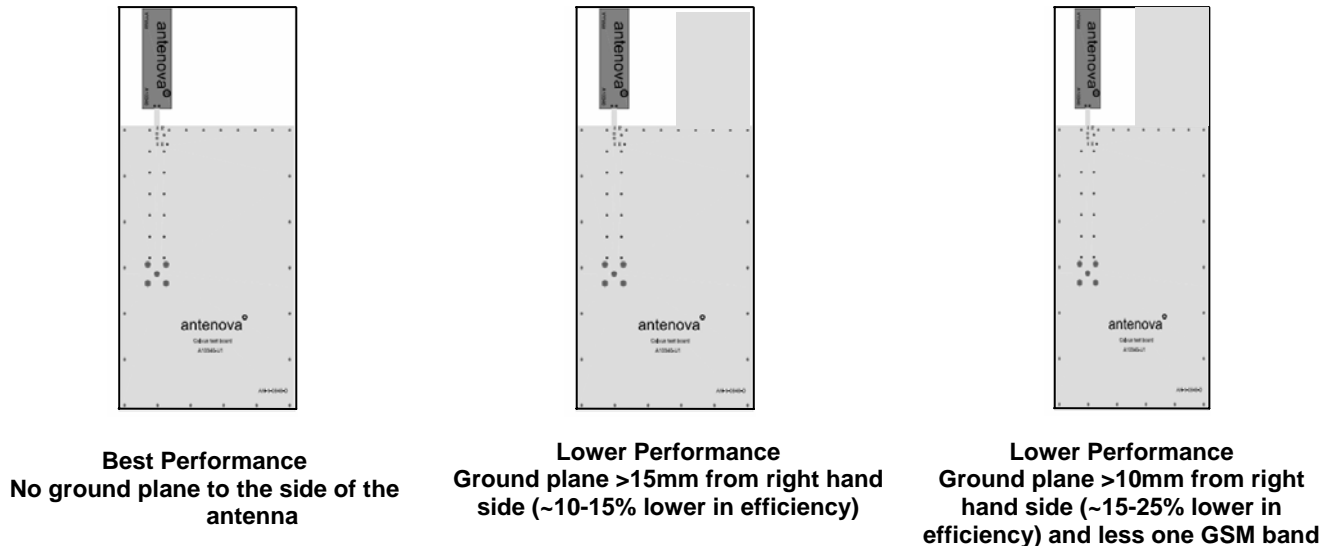
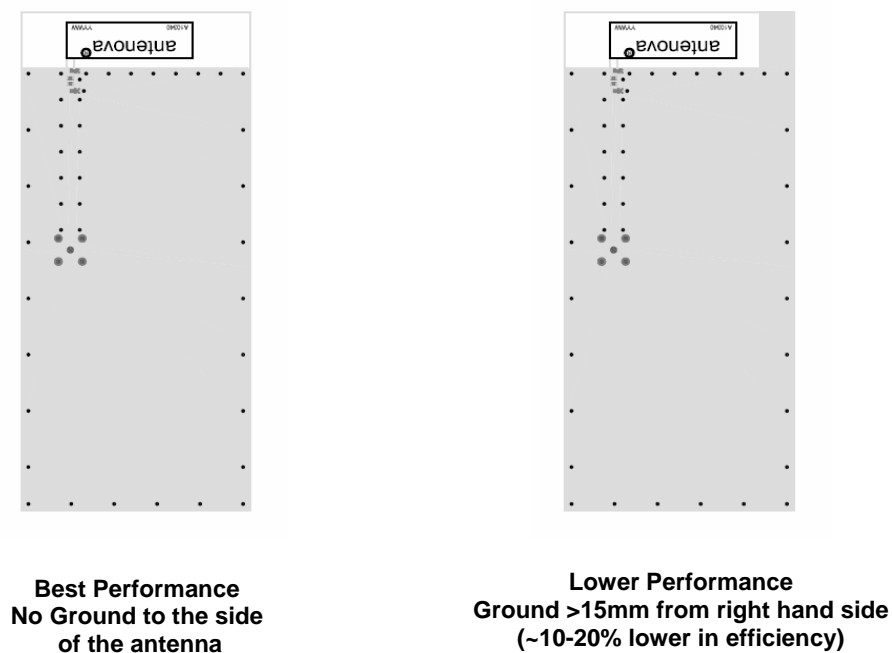

Fig. 7 – (Calvus and Flavus Ground Plane Positions)

Space saving configuration – In this configuration only 3 GSM bands operate (GSM850 or GSM900, DCS and PCS)



Please contact info@antenova for getting the best results from Calvus and Flavus into your product.

5.4. Performance Variation with Ground Plane Length

The test data below shows the affect of different ground plane lengths on the antenna in terms of antenna efficiency on all the GSM and WCDMA bands - see Fig 8.

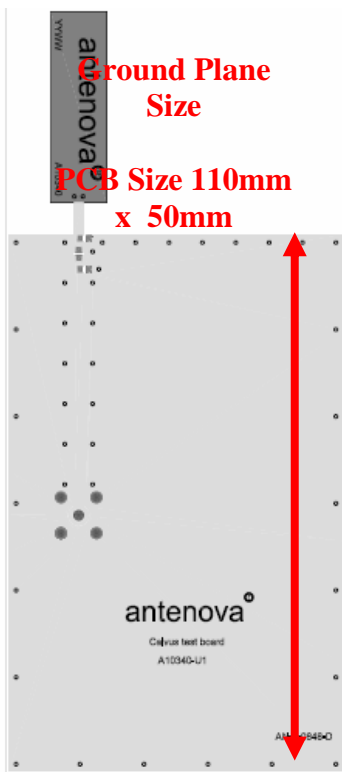

Performance variation vs Gnd Plane Length (GSM850, GSM900)

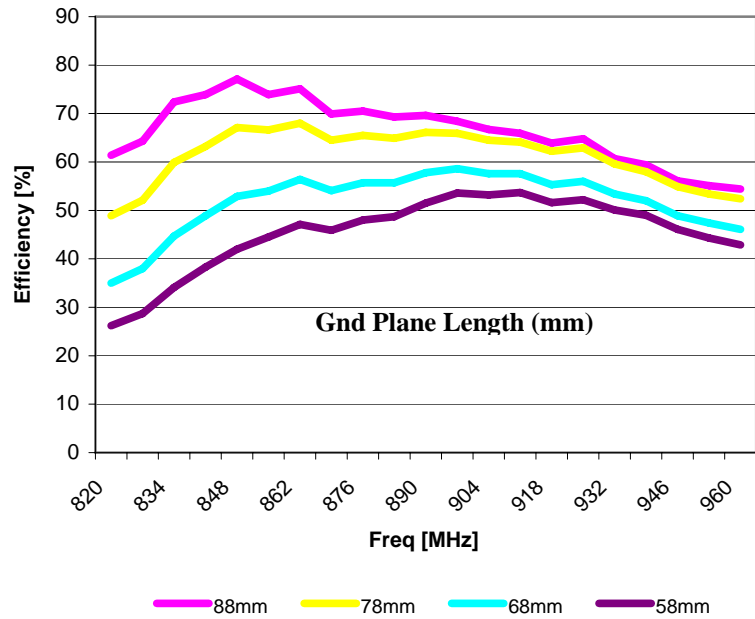
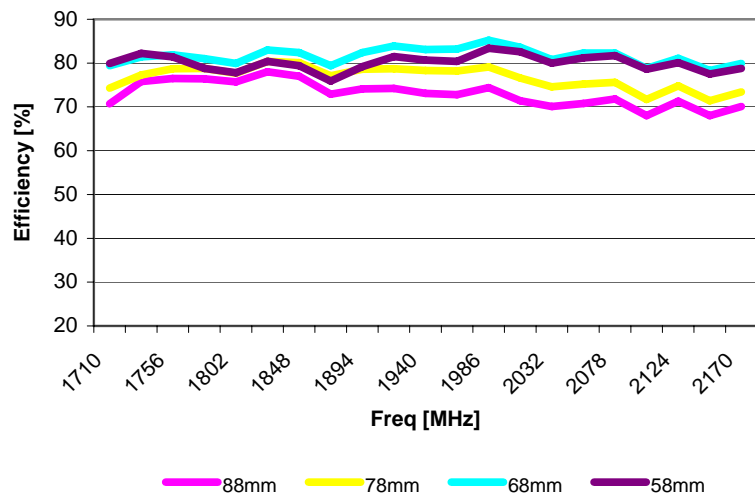

Fig. 8 – Antenna Efficiency Variation (Low-band (above graph), High-band (below graph))

Performance variation vs Gnd Plane Length (DCS, PCS and WCDMA)



6. Designing the antenna feed circuit

Before placing the RF chip relative to the antenna it is important to know what circuits the chip manufacturer requires between them, because many chips have their own particular requirements. According to the chip that is chosen, these may include:

- Nothing – no external circuits are required to support the chip;
- A blocking capacitor;
- A balun, with suggested circuits using discrete components of a half-wavelength loop of transmission line;
- A low-pass filter comprising series L and parallel C. In some circuits the series elements are provided by lengths of transmission line;
- Additional chip-specific circuits to provide bias or control;
- Some combination of these;
- ...and always, an appropriate circuit to match the load presented to the chip to 50 ohms. This load includes the antenna, its feed line and any of the specified additional circuits.

Before doing anything, it is essential to download the chip manufacturer's application note and to take special notice of the requirements for the chip-to-antenna circuit. In all cases enough PCB space must be provided between the chip and the antenna to accommodate these circuits.

On some occasions there may be specific constraints which require that the RF chip and the antenna are mounted some distance apart, connected by a length of transmission line which is significantly long compared with the operating wavelength. Particular care must be exercised in these cases or the efficiency or effective bandwidth of the antenna may be compromised.

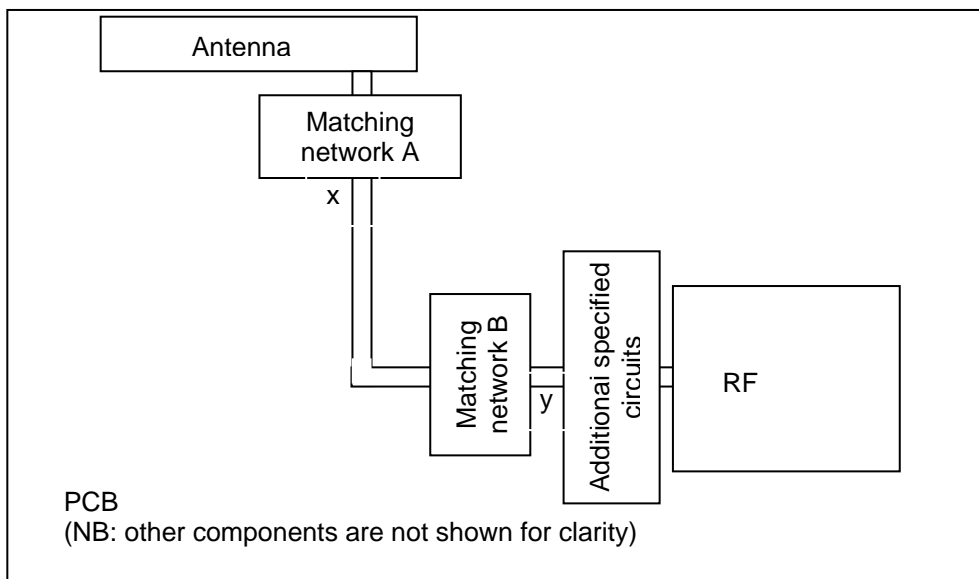

Fig 9: Possible matching network positions. For reference to the additional specified circuits, see above

A typical situation is shown in Fig 9. In general it is best to place the antenna matching circuit close to the antenna (position A), as this minimises loss in the transmission line by ensuring it is operating into a matched impedance. If this is done, then particular care must be taken to ensure that the transmission line x-y is designed to have a uniform 50-ohm characteristic impedance. If the line passes between layers in the PCB, or has additional components joined to it (like static protection diodes), then even though a good match is provided at x the chip may see a mismatched impedance that causes it to malfunction. In this event it is difficult to design a matching circuit that can provide a well-matched impedance at y unless provision is made to put a matching circuit in

Cellular gigaNOVA-09MD-0024-1-AN.doc

position B. Making measurements from y while adjusting a matching circuit at A, seen through a non-uniform line, is not easy; although in principle it is possible to de-embed the intervening line, it is difficult to do this with sufficient accuracy to avoid the necessity of making adjustments by trial and error – not a process to be recommended.

7. Designing the feed line

The RF transmission line connecting the RF chip to the antenna can be designed as a simple micro-strip line (Fig 10a). The width of the track depends only on the thickness and permittivity of the substrate. The RF groundplane may be the bottom layer of the PCB, but any intermediate layer can be used if the right internal connections are provided (see below).

An alternative and more common configuration is a hybrid co-planar waveguide with groundplane. This configuration is more compact than a micro-strip line, but it is necessary to pay careful attention to the bonding of the top and bottom ground planes. The two configurations are shown in Fig 10.

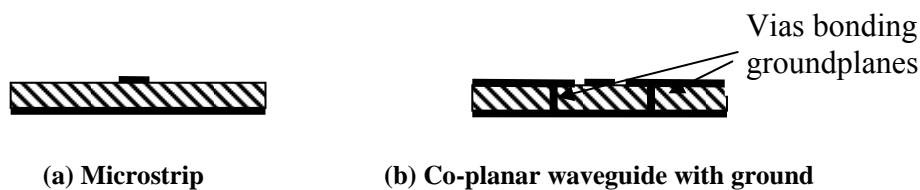

Fig 10: Transmission line configurations

The dimensions of both kinds of transmission lines can be calculated using a simple Windows computer program TXLINE, available free of charge from: <http://www.taconic-add.com/en--downloads.php>

To use this program:

- Download and install it;
- Launch the program;
- Select the tab corresponding to the chosen line configuration;
- Note that the default units may not be the ones you want to use – you may wish to adjust them before you go further
- Enter the permittivity of the PCB material (typically 4.6 for FR4, but less than this for some modern 'high speed' board materials (ignore the material names listed by the program unless you happen to be using one of them – the permittivity you enter will be used)
- Enter the effective board thickness (ie the distance from the RF ground plane to the line conductor).
- Enter the required characteristic impedance (usually 50 ohms)
- If your design uses micro-strip line, press the lower calculation arrow and the required line width is calculated
- If your design used CFW + ground, enter the chosen gap spacing between the line and the upper ground plane (typically between 0.5mm and 1mm); press the lower calculation arrow and the line width is calculated.

It is possible to design the transmission line as an enclosed strip-line in which the 'live' conductor is in an inner layer of the PCB contained between two groundplanes. However, when the line is to be combined with other circuits such as baluns or low pass filters, this configuration is more complex and should probably not be attempted by a designer who is not very familiar with RF circuit design.

Routing the feed line - it is essential that the feed line approaches the antenna feed pad without passing under any of the antenna.

The feed may approach the antenna feed pad from the end of the antenna, or *from the same side as the feed pad*. It must not pass diagonally, or pass from one side to the other, under the antenna.

8. Static control

gigaNOVA antennas which are mounted on top of the groundplane are intrinsically grounded and touching the antenna with a finger will not expose the chip to electrostatic charge. When a series blocking capacitor is fitted this will also provide some protection for the chip. Where an off-the ground plane antenna is used – especially the external models it is recommended that ESD protection is fitted close to the antenna to protect the chip from damage. Fitting it close to the antenna will allow any stray capacitance to be compensated by the matching network.

9. Designing the matching circuit

9.1. Configuration

The matching circuit usually takes the form of an L-C pi- or Tee network connected in series with the antenna, this is usually fine for single band antennas. For the Reflexus and Calvus antennas there is some specialised matching networks needed for 5 band operation, please refer to the data sheet for the matching component layout. For best GSM performance it is also recommended that 0603 (wire wound or non-wire wound type) components are used as these have less loss than the 0402 type. If however space is at a premium then 0402 wire wound components should always be used

9.2. Measurement

The first step is to measure the complex input impedance of the antenna at the output of the matching circuit (ie at the terminal of the matching network that is connected to the antenna).

The equipment necessary to do this is a vector network analyser (VNA), and if you have access to this type of equipment there is little reason why you cannot make the necessary measurements and design the matching network successfully yourself.

If you do not have access to a VNA or do not have anyone available in your organisation who is familiar with its use, Antenova can design your matching network and will be happy to provide a quotation for this service. If you wish to use this service it will simplify matters greatly if you have followed the suggestions contained in this Application Note in the design of your application.

In addition to the VNA and a calibration kit suitable for use at the appropriate frequency, the other equipment you will need comprises:

- A quarter-wave choke fitted with an SMA plug at the open circuit end;
- A short length of UT-47 coaxial cable with a fitted SMA socket.

A suitable quarter-wave choke is shown in Fig 11. It comprises a short length of coaxial cable fitted with an SMA connector at each end – UT141 is ideal for this. A quarter-wavelength piece of copper tube is connected to the outer conductor of the cable at one end and is left open-circuit at the end close to the test item.

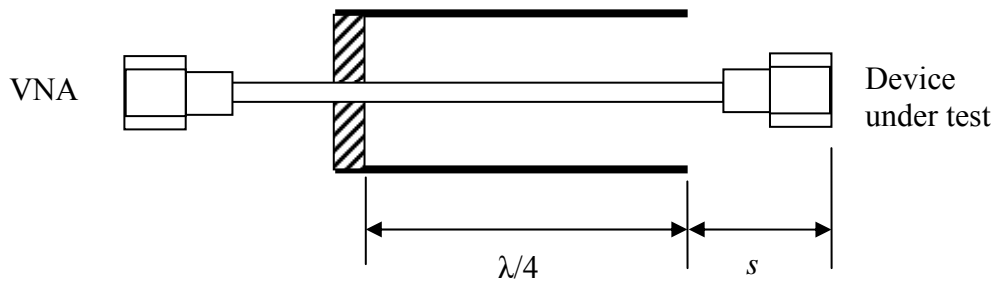

Fig 11: Quarter-wave choke (balun).
Dimension s is kept as short as possible.

The sleeve choke (or balun) is re-usable. Its function is to prevent the cable carrying currents induced by the antenna and inadvertently acting as part of the antenna – in this event the measured impedance is sensitive to the length and position of the cable, when the choke is fitted the measured impedance becomes insensitive to the influence of the cable. If you are interested in a fuller explanation, there is a white paper on the use of baluns for measurement purposes on Antenova’s website.

9.3. Procedure

- a. Cut and form the short terminated length of UT-47 to fit the test board. Make sure that the minimum possible length of inner conductor extends beyond the outer – just enough to make contact with the pad at the input end of the feed (the chip end of the matching network). Connect 0R resistors in the series component spaces between this point and the antenna; do not fit any parallel components. Do not connect the inner at this stage. Ensure the connector overhangs the edge of the board by the minimum distance possible (it is often possible to solder the connector to the ground at the edge of the board.)
- b. Set the VNA *Start* and *Stop* frequencies either side of the band of interest and markers to the lower, centre and upper frequencies of the band. Set the display format to *Smith Chart*
- c. Make sure the *Electrical delay* parameter on the VNA is set to zero.
- d. Attach the balun to the VNA cable and calibrate the VNA to the end of the balun.
- e. Connect the balun to the input of the cable you have just attached to the device under test. The far end of this cable is still open-circuit (as step a).
- f. Increase the *Electrical Delay* on the VNA (usually *Scale/Electrical Delay*) until the displayed plot coalesces into a dot at the open circuit position on the Smith Chart. Record the value of delay that achieves this. (This can be used later if you need to recalibrate the VNA after connecting the cable inner conductor.)
- g. Solder the inner of the test cable to the pad you placed it above (step a).
- h. The VNA is now displaying the complex impedance of the antenna at the point of connection of the matching network.
- i. If you are testing an antenna mounted on a small module, at this stage it is worth experimenting with the environment of the module to examine the variability of the antenna impedance. Once you are satisfied that you understand the variability that may be found in practice, place the module in an environment that provides some kind of typical result – roughly in the middle of the area of the Smith Chart where the plot moved during this experiment.

- j. From the impedance measured, compute the necessary values required for the matching circuit. These can be computed using a program such as *C-Smith*, or *Advanced Automated Smith Chart*, or calculated with the aid of a paper Smith Chart, a ruler, a pair of compasses and a calculator.
- k. Solder the computed components into the matching network, removing the series OR components where necessary.
- l. Measure the input impedance you have now matched and make any necessary component adjustments. Validate the impedance match for various module environments.

Both the bandwidth and the stability of the impedance you will achieve are dependent on the physical size of the module the antenna is mounted on. With very small modules you may need to choose the mounting and/or grounding positions carefully to make it possible to achieve the required bandwidth. This characteristic is typical of any small unbalanced antenna and is not particular to gigaNOVA. A band-edge VSWR of up to 3:1 may be acceptable in these circumstances. A VSWR higher than 3 is probably not desirable as the behaviour of the chip may be degraded by the rapid rate of change of impedance with frequency which is likely to be the result of such a high VSWR. If your application is one which results in a very high operating VSWR you should check the output signal constellation and spurious output of the device.

10. Footnote

We hope this application note is useful in implementing a gigaNOVA cellular SMD antenna in your application. If you have NOT found the information you were looking for, please e-mail us with your queries and we will be delighted to assist you. This application note will be subject to future revisions, so please make sure you visit our web site from time to time so you are sure you have the latest version.



www.antenova.com

Corporate Headquarters

Antenova Ltd.
Far Field House
Albert Road
Stow-cum-Quy
Cambridge
CB25 9AR

Tel: +44 1223 810600
Fax: +44 1223 810650
Email: info@antenova.com

North America Headquarters

Antenova Ltd.
Rogers Business Park
2541 Technology Drive Suite 403
Elgin, IL 60124

Tel: +1 (847) 551 9710
Fax: +1 (847) 551 9719
Email: info@antenova.com

Asia Headquarters

Antenova Asia Ltd.
4F, No. 324, Sec. 1, Nei-Hu Road
Nei-Hu District
Taipei 11493
Taiwan, ROC

Tel: +886 (0) 2 8797 8630
Fax: +886 (0) 2 8797 6890
Email: info@antenova.com

Copyright® 2009 Antenova Ltd. All Rights Reserved. Antenova® and gigaNOVA® are trademarks of Antenova Ltd. Any other names and/or trademarks belong to their respective companies.

The materials provided herein are believed to be reliable and correct at the time of print. Antenova does not warrant the accuracy or completeness of the information, text, graphics or other items contained within this information. Antenova further assumes no responsibility for the use of this information, and all such information shall be entirely at the user's risk.



Certificate No: 4598