

## Scope

This document outlines matters to be considered when designing a product embodying gigaNOVA® antennas; particularly the Indica antenna. These include selecting a suitable location for the antenna, designing the matching circuit and the RF feed between the antenna and the radio chip, and integrating the antenna with other circuits required to support the radio chip. Advice is provided on the measurement techniques and instrumentation to carry out all the design steps; this should help users to establish whether they can carry out the integration in-house or should contact Antenova to make use of our integration service.

### 1 Introduction

gigaNOVA antennas are mostly electrically very small – their longest dimension is much shorter than a quarter wavelength at the operating frequency. For many applications the antenna is mounted on a small printed circuit board, often in close proximity to other components or circuit boards, and with a variety of different connection methods. As a result, the input impedance of the antenna is very dependent on the configuration within which it is used. This situation is not special to gigaNOVA antennas, but is a natural consequence of using antennas in these circumstances.

To provide the best results in any particular application, the designer needs to have some understanding of the possible effects of the configuration on RF performance. Once the configuration is established the performance of the antenna can be optimised by measuring its input impedance in situ, and designing an appropriate matching network so the RF chip is operating into a 50Ω load impedance.

### 2 Selecting and placing an antenna

For applications in the 2.4GHz band, the gigaNOVA product range provides several alternative antennas. The first task is to select the right antenna for the application and to site the antenna on its associated module.

Some antennas are mounted in an area clear of copper groundplane area of the PCB, (Models: **Mixtus, Rufa, Impexa, Fusca and Indica**). These antennas generate electromagnetic fields of similar intensity on both sides of the PCB on which they are mounted. They will provide excellent results for applications in which the local fields created by the antenna will be clear of other circuit boards, metallic objects or interconnecting cables.

Antennas mounted on the local groundplane (Models: **Mica and Comata**) excite strong fields on the side of the board where they are mounted, but the fields behind the board are lower, so these antennas are more tolerant of situations in which a small radio module is mounted parallel with a larger motherboard or a conductive consumer device (Fig 1). The impedance of these antennas will vary with their placement on the board – the distance from the antenna to the edge of the board and its position relative to the board corners.

The swivel-style antennas (Models: **Picea and Titanis**) are designed to be mounted on the edge of the groundplane at a position at which there is only a small mechanical clearance between the groundplane and the enclosure/cabinet of the equipment. The styling of the cabinet needs to provide freedom for the antenna to be raised to its operating position without obstruction.

### 3 Antennas on small RF modules

As a rule of thumb, the smaller the PCB on which an antenna is mounted, the more sensitive the performance of the antenna will be to the environment in which the PCB mounted, and the way it is connected. Things become rapidly more critical when the longest dimension of the PCB is less than about half a wavelength (~ 60mm at 2.5GHz). If the module carrying the antenna is mounted on a motherboard (or on the conductive surface of a host

device), the groundplane of the module should be grounded at a fixed point to the motherboard. A flexible data connection is not a good RF ground, because the RF performance of the module is likely to vary according to the way the connection is routed. If the module is connected using a multi-pole connector it is good practice to provide ground pins at both ends of the connector. Fig 2 shows some typical arrangements.

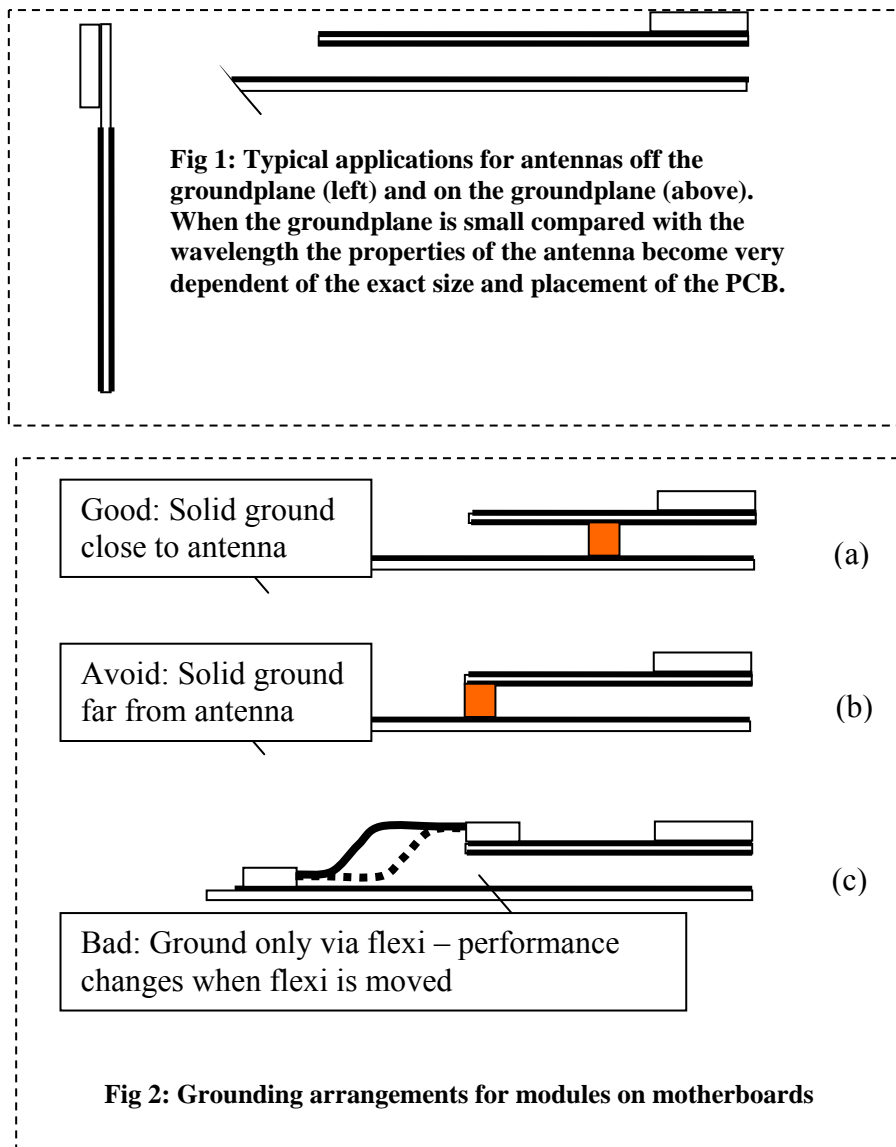

The space between an RF module and its motherboard will always tend to be 'lively'; the arrangement in Fig 2(a) shows solid ground point(s) around the middle of a small module. Assuming only two ground connections will be provided (for economic reasons), this is probably the best method. The ground connections could be made through connector pins or using screws with bushes in contact with the groundplane of the module.

The arrangement of Fig 2(b) in which the ground point is remote from the antenna is likely to be more problematical because the module will itself operate as an antenna – especially if the overhang from the ground point is around a quarter wavelength. In this event the input impedance of the antenna will be strongly influenced by the connection geometry and the radiation pattern of the 'real' antenna and the module (operating together) may not be what is expected.

The arrangement of Fig 2(c) in which the only ground connection is made via an interconnecting cable or flexi-PCB is always to be avoided. A long flexible connection is an unsuitable RF ground: the antenna impedance will vary according to the exact disposition of the connection, and it is probable that RF currents will be coupled into data and other lines, reducing the RF efficiency of the system.

#### 4 Antenna Location

In order to create an optimized layout for Indica the antenna's performance behaviour is controlled by many variables in the surrounding environment. Antenova has determined several rules are important to take into account when designing a product using the Indica A10381 antenna.

1. Long side of antenna must be along the edge of the ground plane.
2. Ground plane is removed from all layers below the antenna.
3. The distance from the antenna to the enclosure or plastic cover, should be greater than >1.5mm.
4. The distance from the antenna to relatively large perturbations, such as a nearby shield or large components, is dependent on the height of surrounding components, but should not be less than 1.5mm from the edge of the antenna clearance area. A chart (Fig. 3) shows the component distance from the antenna area vs the component height this should be used as a guide.
5. The minimum distance of the antenna clearance area to either end of the PCB is equal to or greater than 8mm, with better performance from larger distances. Because of the MDA antenna's high performance, some designs may allow for smaller distances. Please email Antenova for more details regarding a customised layout

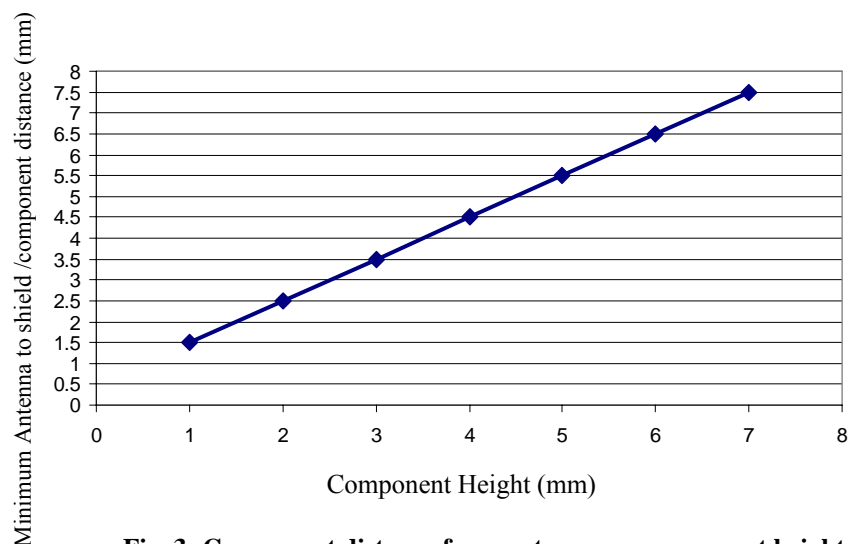
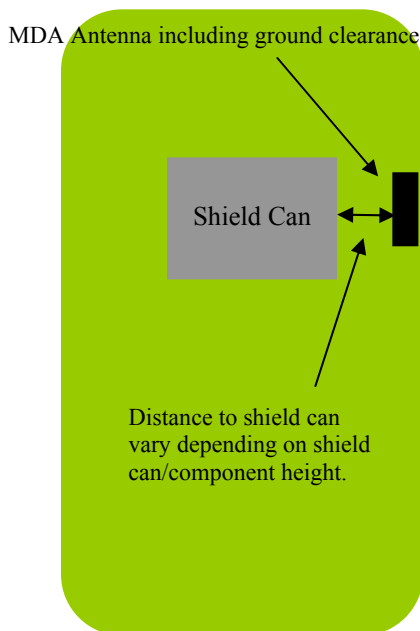
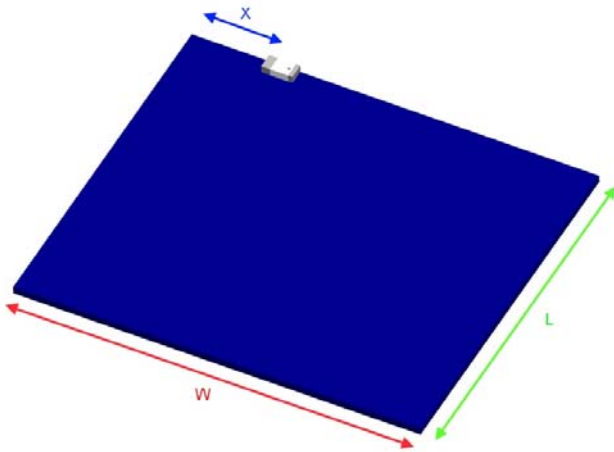

**Fig. 3: Component distance from antenna vs. component height**

The effect of infringing the suggested limit will be a progressive reduction of the impedance bandwidth of the antenna and an increased risk of loss of RF energy by coupling into other circuits. It is very difficult to provide hard quantitative guidelines because of interactions between the antenna, the PCB dimensions and the particular layout, component types and circuit functions of the relevant components. Detailed electromagnetic modelling is possible, but it is very expensive to model a complex circuit in the necessary detail, especially when some of the interactions involve complex digital ICs.

## 5 Performance Variations

This section of the application note is intended to provide information on how performance varies outside the conditions used to measure the data of the Indica antenna on the reference board. The position "X" refers to the edge of the PCB and edge of the ground plane clearance area of the antenna (Fig. 4).



W=42, L=36, X=8 (all in mm) – Example 1

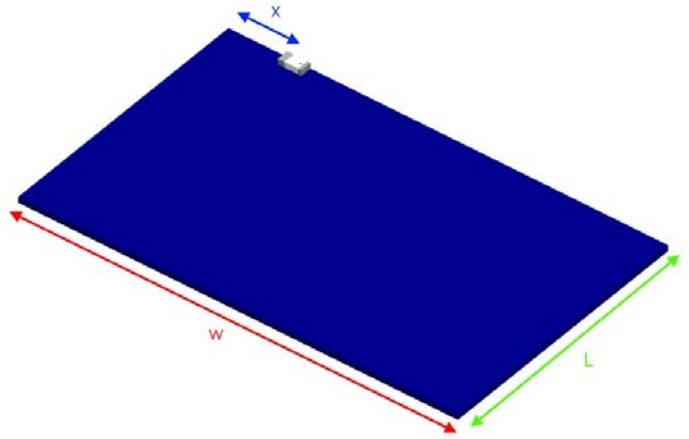

W=60, L=36, X=8 (all in mm) – Example 2

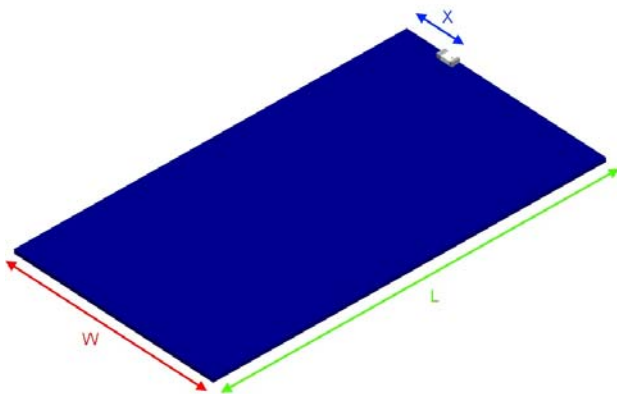

W=42, L=75, X=8 (all in mm) – Example 3

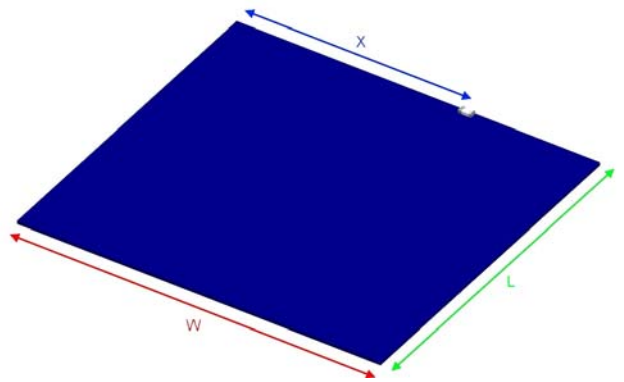

W=90, L=75, X=56 (all in mm) – Example 4

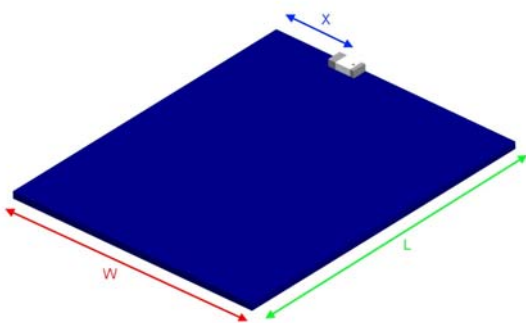

W=30, L=36, X=8 (all in mm) – Example 5

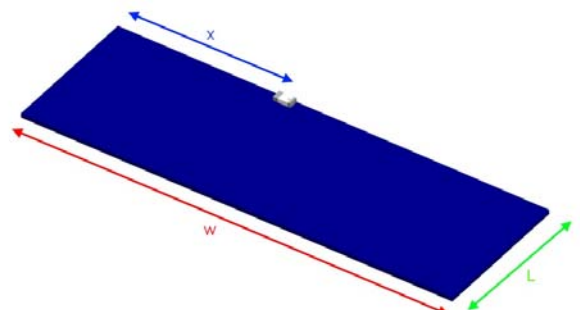

W=80, L=24, X=30 (all in mm) – Example 6

Performance data for the variation examples 1 - 6

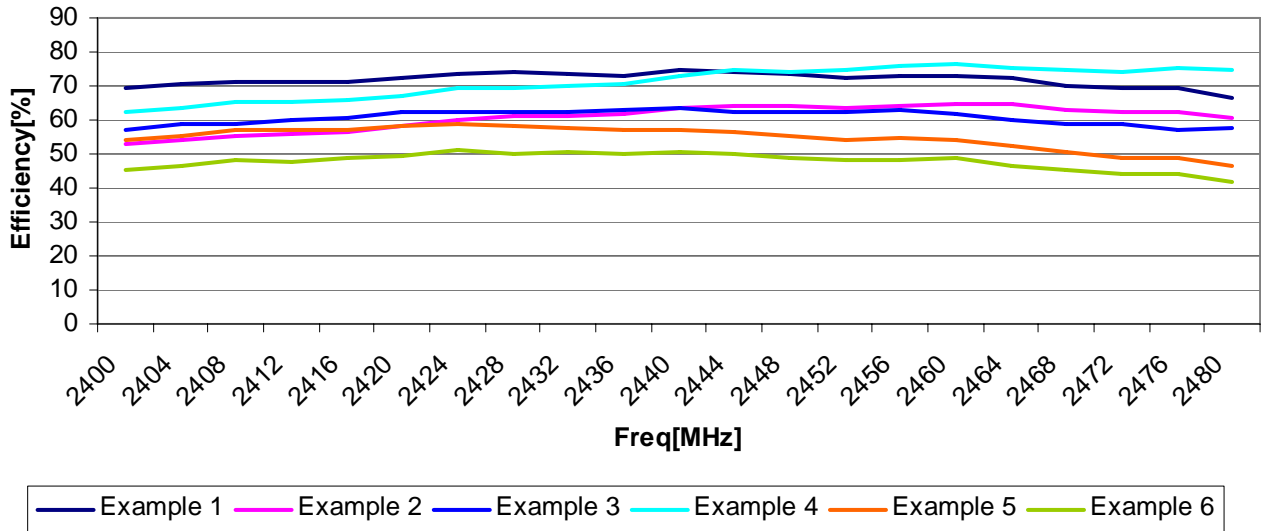

The performances shown in the above graph was measured without a proper optimised matching circuit. Using an optimised matching circuit could yield up to 5% - 10% performance increase especially at the band edges,

Fig. 4: Performance variations

## 6 Designing the antenna feed circuit

Before placing the RF chip relative to the antenna it is important to know what circuits the chip manufacturer requires between them, because many chips have their own particular requirements. According to the chip that is chosen, these may include:

- a. Nothing – no external circuits are required to support the chip;
- b. A blocking capacitor;
- c. A balun, with suggested circuits using discrete components of a half-wavelength loop of transmission line;
- d. A low-pass filter comprising series L and parallel C. In some circuits the series elements are provided by lengths of transmission line;
- e. Additional chip-specific circuits to provide bias or control
- f. Some combination of these
- g. ...and always, an appropriate circuit to match the load presented to the chip to 50 ohms. This load includes the antenna, its feed line and any of the specified additional circuits.

Before doing anything, it is essential to download the chip manufacturer's application note and to take special notice of the requirements for the chip-to-antenna circuit. In all cases enough PCB space must be provided between the chip and the antenna to accommodate these circuits.

On some occasions there may be specific constraints which require that the RF chip and the antenna are mounted some distance apart, connected by a length of transmission line which is significantly long compared with the operating wavelength. Particular care must be exercised in these cases or the efficiency or effective bandwidth of the antenna may be compromised.

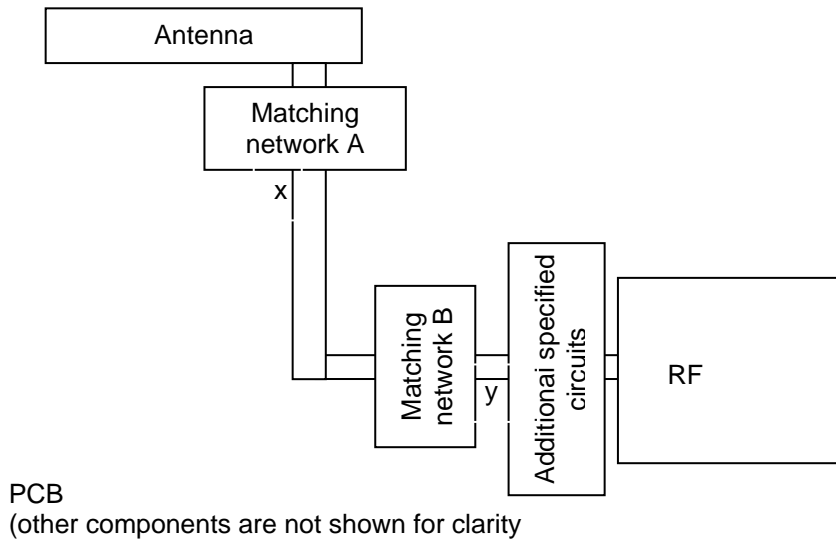

**Fig 5: Possible matching network positions. For reference to the additional specified circuits, see above**

A typical situation is shown in Fig 5. In general it is best to place the antenna matching circuit close to the antenna (position A), as this minimises loss in the transmission line by ensuring it is operating into a matched impedance. If this is done, then particular care must be taken to ensure that the transmission line x-y is designed to have a uniform 50-ohm characteristic impedance. If the line passes between layers in the PCB, or has additional components joined to it (like static protection diodes), then even though a good match is provided at x the chip may see a mismatched impedance that cause it to malfunction. In this event it is difficult to design a matching circuit that can provide a well-matched impedance at y unless provision is made to put a matching circuit in position B. Making measurements from y while adjusting a matching circuit at A, seen through a non-uniform line, is not easy; although in principle it is possible to de-embed the intervening line, it is difficult to do this with sufficient accuracy to avoid the necessity of making adjustments by trial and error – not a process to be recommended.

## 7 Designing the feed line

The RF transmission line connecting the RF chip to the antenna can be designed as a simple microstrip line (Fig 6a). The width of the track depends only on the thickness and permittivity of the substrate. The RF groundplane may be the bottom layer of the PCB, but any intermediate layer can be used if the right internal connections are provided (see below).

An alternative and more common configuration is a hybrid co-planar waveguide with groundplane. This configuration is more compact than a microstrip line, but it is necessary to pay careful attention to the bonding of the top and bottom groundplanes. The two configurations are shown in Fig 5.

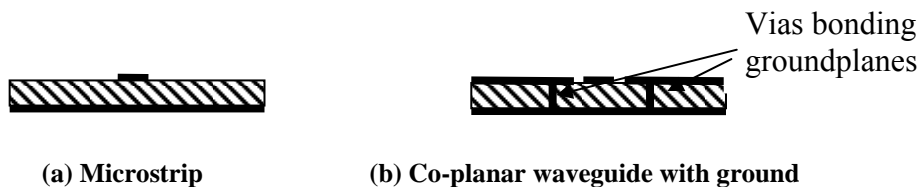

**Fig 6: Transmission line configurations**

The dimensions of both kinds of transmission line can be calculated using a simple Windows computer program TXLINE, available free of charge from: <http://www.taconic-add.com/en--downloads.php>

To use this program:

- Download and install it;
- Launch the program;
- Select the tab corresponding to the chosen line configuration;
- Note that the default units may not be the ones you want to use – you may wish to adjust them before you go further
- Enter the permittivity of the PCB material (typically 4.6 for FR4, but less than this for some modern 'high speed' board materials (ignore the material names listed by the program unless you happen to be using one of them – the permittivity you enter will be used)
- Enter the effective board thickness (ie the distance from the RF groundplane to the line conductor).
- Enter the required characteristic impedance (usually 50 ohms)
- If your design uses microstrip line, press the lower calculation arrow and the required line width is calculated
- If your design used CFW + ground, enter the chosen gap spacing between the line and the upper groundplane (typically between 0.5mm and 1mm); press the lower calculation arrow and the line width is calculated.

It is possible to design the transmission line as an enclosed stripline in which the 'live' conductor is in an inner layer of the PCB contained between two groundplanes. However, when the line is to be combined with other circuits such as baluns or low pass filters, this configuration is more complex and should probably not be attempted by a designer who is not very familiar with RF circuit design.

**Routing the feed line** - it is essential that the feed line approaches the antenna feed pad without passing under any of the antenna.

- For off groundplane models (Models: **Mixtus, Rufa, Impexa, Fusca and Indica**), the feed may approach the antenna feed pad from the end of the antenna, or *from the same side as the feed pad*. It must not pass diagonally, or pass from one side to the other, under the antenna. Left- and right-hand versions of these models are available to suit your application – for clarification of which is which, please see the Product Specification.
- For on-groundplane models the feed line **MUST** approach the antenna at right angles to its axis; for these models it does not matter from which side.

## 8 Static control

gigaNOVA antennas which are mounted on top of the groundplane are intrinsically grounded and touching the antenna with a finger will not expose the chip to electrostatic charge. When a series blocking capacitor is fitted this will also provide some protection for the chip. Where an off-the groundplane antenna is used – especially the external models (Picea and Titanis) it is recommended that ESD protection is fitted close to the antenna to protect the chip from damage. Fitting it close to the antenna will allow any stray capacitance to be compensated by the matching network.

## 8 Designing the matching circuit

### 8.1 Configuration

The matching circuit usually takes the form of an L-C pi- or Tee network connected in series with the antenna. This is often configured as a low-pass network (with series L and parallel C) because this configuration tends to reduce the levels of any emitted harmonics which the chip may produce.

When designing the first version of the PCB it is good practice to include the necessary accommodation for two series and two parallel components, allowing freedom to configure the matching circuit as required.

### 8.2 Measurement

The first step is to measure the complex input impedance of the antenna at the output of the matching circuit (ie at the terminal of the matching network that is connected to the antenna).

The equipment necessary to do this is a vector network analyser (VNA), and if you have access to this type of equipment there is no reason why you cannot make the necessary measurements and design the matching network successfully yourself.

If you do not have access to a VNA or do not have anyone available in your organisation who is familiar with its use, Antenova can design your matching network and will be happy to provide a quotation for this service. If you wish to use this service it will simplify matters greatly if you have followed the suggestions contained in this Application Note in the design of your application.

In addition to the VNA and a calibration kit suitable for use at the appropriate frequency, the other equipment you will need comprises:

- A quarter-wave choke fitted with an SMA plug at the open circuit end;
- A short length of UT-47 coaxial cable with a fitted SMA socket.

A suitable quarter-wave choke is shown in Fig 7. It comprises a short length of coaxial cable fitted with an SMA connector at each end – UT141 is ideal for this. A quarter-wavelength piece of copper tube is connected to the outer conductor of the cable at one end and is left open-circuit at the end close to the test item.

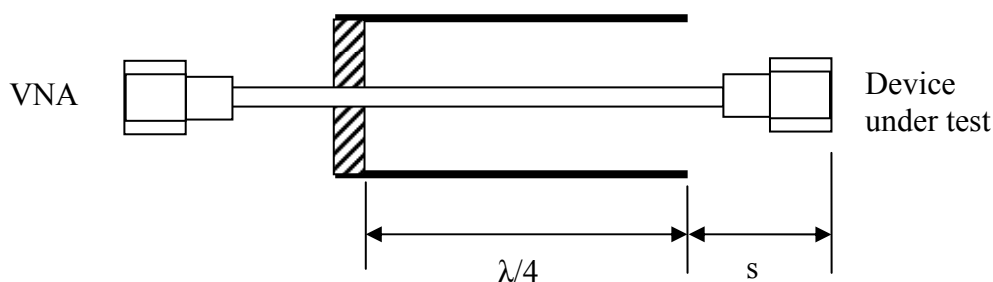

**Fig 7: Quarter-wave choke (balun).**  
**Dimension s is kept as short as possible.**

The sleeve choke (or balun) is re-usable. Its function is to prevent the cable carrying currents induced by the antenna and inadvertently acting as part of the antenna – in this event the measured impedance is sensitive to the length and position of the cable, when the choke is fitted the measured impedance becomes insensitive to the influence of the cable. If you are interested in a fuller explanation, there is a white paper the use of baluns for measurement purposes on Antenova's website.

### 8.2.1 Procedure

- a. Cut and form the short terminated length of UT-47 to fit the test board. Make sure that the minimum possible length of inner conductor extends beyond the outer – just enough to make contact with the pad at the input end of the feed (the chip end of the matching network). Connect 0R resistors in the series component spaces between this point and the antenna; do not fit any parallel components. Do not connect the inner at this stage. Ensure the connector overhangs the edge of the board by the minimum distance possible (it is often possible to solder the connector to the ground at the edge of the board.)
- b. Set the VNA *Start* and *Stop* frequencies either side of the band of interest and markers to the lower, centre and upper frequencies of the band. Set the display format to *Smith Chart*
- c. Make sure the *Electrical delay* parameter on the VNA is set to zero.
- d. Attach the balun to the VNA cable and calibrate the VNA to the end of the balun.
- e. Connect the balun to the input of the cable you have just attached to the device under test. The far end of this cable is still open-circuit (as step a).
- f. Increase the *Electrical Delay* on the VNA (usually *Scale/Electrical Delay*) until the displayed plot coalesces into a dot at the open circuit position on the Smith Chart. Record the value of delay that achieves this. (This can be used later if you need to recalibrate the VNA after connecting the cable inner conductor.)
- g. Solder the inner of the test cable to the pad you placed it above (step a).
- h. The VNA is now displaying the complex impedance of the antenna at the point of connection of the matching network.
- i. If you are testing an antenna mounted on a small module, at this stage it is worth experimenting with the environment of the module to examine the variability of the antenna impedance. Once you are satisfied that you understand the variability that may be found in practice, place the module in an environment that provides some kind of typical result – roughly in the middle of the area of the Smith Chart where the plot moved during this experiment.
- j. From the impedance measured, compute the necessary values required for the matching circuit. These can be computed using a program such as *C-Smith*, or *Advanced Automated Smith Chart*, or calculated with the aid of a paper Smith Chart, a ruler, a pair of compasses and a calculator.
- k. Solder the computed components into the matching network, removing the series 0R components where necessary.
- l. Measure the input impedance you have now matched and make any necessary component adjustments. Validate the impedance match for various module environments.

Both the bandwidth and the stability of the impedance you will achieve are dependent on the physical size of the module the antenna is mounted on. With very small modules you may need to choose the mounting and/or grounding positions carefully to make it possible to achieve the required bandwidth. This characteristic is typical of any small unbalanced antenna and is not particular to gigaNOVA. A band-edge VSWR of up to 3:1 may be acceptable in these circumstances. A VSWR higher than 3 is probably not desirable as the behaviour of the chip may be degraded by the rapid rate of change of impedance with frequency which is likely to be the result of such a high VSWR. If your application is one which results in a very high operating VSWR you should check the output signal constellation and spurious output of the device.

## 9 Footnote

We hope this application note is useful in implementing Indica A10381 antenna in your application. If you have NOT found the information you were looking for, please e-mail us with your queries and we will be delighted to assist you. This application note will be subject to future revisions, so please make sure you visit our web site from time to time so you are sure you have the latest version.



**[www.antenova.com](http://www.antenova.com)**

**Corporate Headquarters**

Antenova Ltd.  
Far Field House  
Albert Road  
Stow-cum-Quy  
Cambridge  
CB25 9AR

**Tel:** +44 1223 810600  
**Fax:** +44 1223 810650  
**Email:** [info@antenova.com](mailto:info@antenova.com)

**North America Headquarters**

Antenova Ltd.  
Rogers Business Park  
2541 Technology Drive Suite 403  
Elgin, IL 60124

**Tel:** +1 (847) 551 9710  
**Fax:** +1 (847) 551 9719  
**Email:** [info@antenova.com](mailto:info@antenova.com)

**Asia Headquarters**

Antenova Asia Ltd.  
4F, No. 324, Sec. 1, Nei-Hu Road  
Nei-Hu District  
Taipei 11493  
Taiwan, ROC

**Tel:** +886 (0) 2 8797 8630  
**Fax:** +886 (0) 2 8797 6890  
**Email:** [info@antenova.com](mailto:info@antenova.com)

**Copyright® 2011 Antenova Ltd.** All Rights Reserved. Antenova® and gigaNOVA® are trademarks of Antenova Ltd. Any other names and/or trademarks belong to their respective companies.

The materials provided herein are believed to be reliable and correct at the time of print. Antenova does not warrant the accuracy or completeness of the information, text, graphics or other items contained within these information. Antenova further assumes no responsibility for the use of this information, and all such information shall be entirely at the user's risk.



Certificate No: 4598