

Scope

This document outlines matters to be considered when designing a product embodying multiple Mixtus A10194 antennas to enable multiple-input multiple-output (MIMO) operations. MIMO is a way of significantly increasing the maximum data rate of a communication channel over that of a system having a single transmit and receive antenna. The IEEE 802.11n wireless networking standard incorporates MIMO operations.

1 Mixtus

Mixtus is the latest member of the Antenova gigaNOVA[®] family of standard antennas, which are characterised by being electrically small – their longest dimension is much shorter than a quarter wavelength at the operating frequency. Mixtus A10194 antenna is a high efficiency dual-band 2.4 GHz and 5 GHz antenna suitable for a wide range of consumer Wi-Fi applications, including 802.11n MIMO applications.

Mixtus A10194 is a compact, SMD mounted antenna measuring 10 x 10 x 0.9 mm and requires minimal ground plane. Further details of the antenna, including product specifications, may be found on the Antenova website Resources section. Some general guidance on using gigaNOVA antennas may be found in the gigaNOVA Application Note which is also available on the Antenova website Resources section. This Application Note gives guidance on selecting a suitable location for the antenna, designing the matching circuit and the RF feed between the antenna and the radio chip, and on integrating the antenna with other circuits required to support the radio chip. Advice is also provided on the measurement techniques and instrumentation to carry out all the design steps. You will need to log in to the Antenova website to view the most recent version of this document.

2 MIMO

In a communication system, the maximum amount of information that can be reliably transmitted over a communications channel is known as the channel capacity. Traditionally, communication systems, such as WLAN systems, have used a single transmitting antenna and a single receiving antenna. This has become known as Single Input, Single Output (SISO) architecture. For a SISO communication system the channel capacity is determined solely by the bandwidth available and the signal to noise ratio in a formula known as the Shannon–Hartley theorem.

In the last decade it has been found that if several antennas are used for transmission and several are used for reception, then in a multi-path propagation environment there are many different radio paths available between different combinations of transmitting and receiving antennas. In this environment the channel capacity may exceed the single antenna case. The total available data rate increases with the number of antennas used, in a complex manner dependent on both the environment and the characteristics of the antennas. Known as MIMO, this technique is an attractive solution to the problem of increasing data rates across a communications link without requiring more bandwidth to accommodate the signal or more transmitted power to increase the signal to noise ratio.

With a SISO system, multi-path creates problems with signal fading but MIMO systems are designed to exploit a rich multi-path environment to increase the data rate. In a typical MIMO system, a high speed data bit stream is de-multiplexed into several slower bit streams that are then coded and sent to separate transmitters, each with its own antenna. Because of the multi-path environment, all the receivers used in a MIMO system will collect the multiple transmission streams. Signal processing is used to decode the received signals and recover the data which is then multiplexed to recreate the original bit stream.

MIMO may be implemented with any number of transmitting and receiving antennas (greater than 1) and the numbers of transmitting and receiving antennas do not have to be equal. Many modern WLAN MIMO systems

make use of 3 antennas for both transmit and receive, and this is the case that we have investigated in this application note. For MIMO to work effectively, the set of transmitting or receiving antennas must see different multi-path signal sets; this implies that the antennas must not be too closely coupled together (i.e. they must have good isolation between them) and they must have some 'diversity', meaning in practice, that they must have different beam patterns or polarizations or be spatially separated.

The use of MIMO does not constrain the signal modulation format and a number of modern systems combine MIMO with OFDM or OFDMA schemes.

3 Experimental setup

We have envisaged a scenario where a central communication device, such as a set top box, is used to stream video to a number of receiving devices. The transmitters and receivers each use a MIMO antenna system consisting of three dual-band antennas working simultaneously in the 2400-2500 MHz and 5100-5800 MHz frequency bands.

Two different antenna arrangements were investigated experimentally to determine the extent to which:

- Isolation was possible between the antennas
- Some form of antenna diversity could be created
- Antenna efficiency was maintained, despite the presence of other antennas and other devices

A further practical consideration is that a set top box may well be used in a situation where several devices are stacked on top of each other (DVD player, game console, TV, etc). This situation could mean that in effect there is an extra layer of metal placed immediately above the antenna system as well as the PCB of the set up box itself. To investigate this possibility, set-up 2 was tested with a metal sheet 17 mm under the antennas and another one 17 mm above the antennas.

4 Set-up 1, free space

The first test arrangement used a PCB with maximum dimensions 80 x 115 mm with 10.5 mm of groundplane cleared underneath the antennas at each end of the PCB. The antenna were placed in three corners of the PCB, two on the same face of the PCB and one on the reverse face, see figure 1.

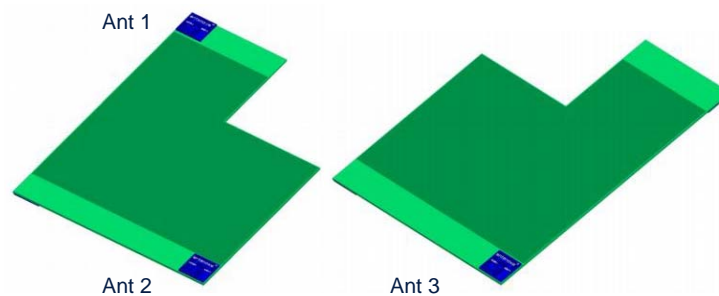

Fig 1: The layout of set-up 1: Left - top side, right - underside of PCB.

All tests using this arrangement were performed in free space. The return loss at the input of the matching circuit was measured using an Agilent ENA E5071B RF Network Analyser. For all measurements, a 2.4 GHz RF sleeve choke was used to reduce the effect of the cable radiation, see figure 2.



Figure 2 - RF Choke for measurements.

The return loss and average efficiency for the three antennas is shown in Table 1. It can be seen that high average efficiency has been maintained with this arrangement of 3 antennas.

Set-up 1, Summary of Results Free Space				
		Antenna 1	Antenna 2	Antenna 3
Return Loss	2.4-2.5 GHz	< -13.1 dB	< -12.5 dB	< -12.7 dB
	5.1-5.8 GHz	< -10.6dB	< -10.5 dB	< -10.8 dB
Average Efficiency	2.4-2.5 GHz	67.5%	77.1%	69.7%
	5.1-5.8 GHz	73.3%	63.8%	64.9%

Table 1: Return Loss and efficiency for the three antennas of set-up 1.

The isolation between the three antennas was found to be substantial, see Table 2. As might be expected the isolation between antennas 2 and 3 is smaller than for 1-2 and 1-3 because they are closer together. Nonetheless this isolation is sufficient for MIMO operation.

Set-up 1, Summary of Results Free Space				
		Antenna 1-2	Antenna 1-3	Antenna 2-3
Isolation	2.4-2.5 GHz	< 37.2 dB	< 37.5 dB	< 11.7 dB
	5.1-5.8 GHz	< 39.0dB	< 35.7 dB	< 13.3 dB

Table 2: Isolation between the three antennas of set-up 1.

High isolation between two antennas does not of itself guarantee that diversity is obtained. However, inspection of the 3-D radiation patterns given in the Appendix show that the two closest antennas 2 & 3 are effectively radiating in opposite directions and there is good spatial diversity between these antennas and antenna 1, their separation being almost a wavelength.

5 Set-up 2, free space

The second test arrangement used a PCB with maximum dimensions 82 x 82 mm, again with groundplane cleared underneath the antennas. The antennas were placed in three corners of the PCB, two on the same face of the PCB and one on the reverse face, see figure 3. All tests using this arrangement were performed in free space. It was thought that although set-up 2 is more compact than set-up 1, this particular arrangement might still have high isolation and offer advantages in cost reduction through the use of a smaller PCB

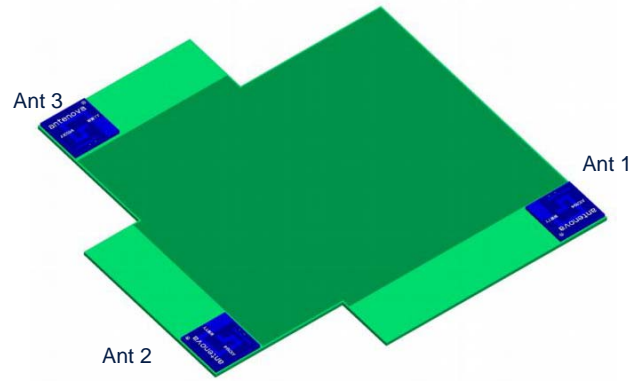

Fig 3: The layout of set-up 2

The return loss and average efficiency for the three antennas is shown in Table 1. Again, it can be seen that the average efficiency is above 60% for this arrangement of the antennas.

Set-up 2, Summary of Results Free Space				
		Antenna 1	Antenna 2	Antenna 3
Return Loss	2.4-2.5 GHz	< -9.2 dB	< -12.5 dB	< -14.2 dB
	5.1-5.8 GHz	< -10.8 dB	< -8.3 dB	< -10.0 dB
Average Efficiency	2.4-2.5 GHz	65.9%	66.7%	67.3%
	5.1-5.8 GHz	67.5%	65.2%	65.0%

Table 3: Return Loss and efficiency for the three antennas of set-up 2.

The isolation between the three antennas was found to be high in this set-up, see Table 4. This isolation is sufficient for MIMO operation

Set-up 2, Summary of Results Free Space				
		Antenna 1-2	Antenna 1-3	Antenna 2-3
Isolation	2.4-2.5 GHz	< 14.2 dB	< 18.6 dB	< 14.6 dB
	5.1-5.8 GHz	< 23.2dB	< 27.2 dB	< 22.3 dB

Table 4: Isolation between the three antennas of set-up 2.

Inspection of the three 3-D radiation patterns given in the Appendix show that again they are substantially different giving the potential for good diversity.

6 Set-up 2a, metal sheet under PCB

Set-up 2 was also tested with a solid metal sheet underneath the antennas and a distance of 17 mm between the antennas and the metal under them. This arrangement, 2a, was intended to reproduce the situation when the antennas are integrated in a real device, as shown in Figure 4. The results, see table 5, show that the efficiency of the antennas is reduced slightly but is still greater than 50% for all 3 antennas in both bands.

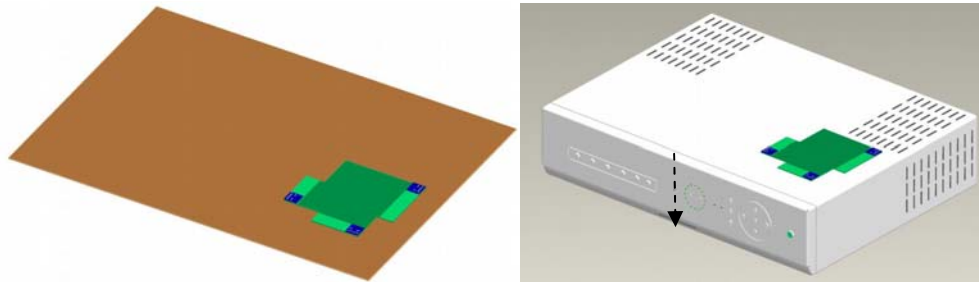

Fig 3: The layout of set-up 2a. The left hand picture shows the test arrangement and the right hand picture shows the scenario is intended to represent. Another box, e.g. a DVD player, might be placed on top of this box.

Set-up 2a, Summary of Results Metal sheet 17 mm under PCB				
		Antenna 1	Antenna 2	Antenna 3
Return Loss	2.4-2.5 GHz	< -7.1 dB	< -9.3 dB	< -10.2 dB
	5.1-5.8 GHz	< -9.2 dB	< -9.2 dB	< -11.5 dB
Average Efficiency	2.4-2.5 GHz	52.3%	54.7%	56.5%
	5.1-5.8 GHz	64.6%	62.4%	67.5%

Table 5: Return Loss and efficiency for the three antennas of set-up 2a.

7 Conclusions

The latest member of the Antenova gigaNOVA family of standard antennas is the Mixtus A10194, an efficient dual-band 2.4 GHz and 5 GHz antenna suitable for a wide range of consumer Wi-Fi applications. Because MIMO operation is becoming increasingly important, and is provided for in the 802.11n protocol, Antenova has tested an array of three Mixtus antennas to find out if sufficient antenna efficiency and isolation between antennas could be achieved. The results are very encouraging, except for the case when one antenna is inside a host box, instead of being near the edge, and has grounded conducting planes above and below it. Even in this situation however, the 5 GHz performance was adequate and most MIMO applications involve the 5 GHz band rather than the 2.4 GHz band.

8 Acknowledgement

The author is grateful to his former colleague Raul Recio for carrying out the measurements reported above.

9 Footnote

We hope this application note will be useful to you in implementing a MIMO system using Mixtus antennas. If you have NOT found the information you were looking for, please e-mail us (info@antenova.com) with your queries and we will be delighted to assist you. This application note may be subject to future revisions, so please make sure you visit our web site from time to time so you are sure you have the latest version.

10 Useful References:

[1] G.J. Foschini and M.J. Gans, "On Limits of Wireless Communications in a Fading Environment when Using Multiple Antennas", *Wireless Personal Communications*, Published by Springer Netherlands, Vol 6, No 3, March, 1998, pp 311-335

[2] S. M. Alamouti, "A simple transmit diversity technique for wireless communications", *IEEE J. Select Areas of Comms.*, Vol 16, No 8, Oct 1998, pp 1451 - 1458.

Appendix - 3D Radiation Patterns

Set-up 1, free space

Antenna 1

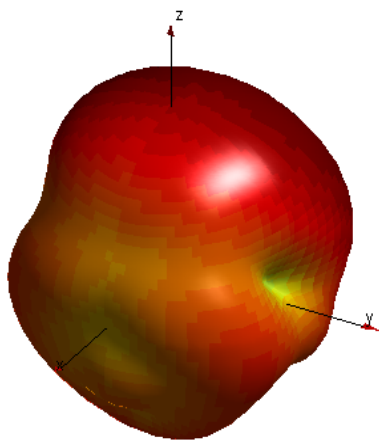
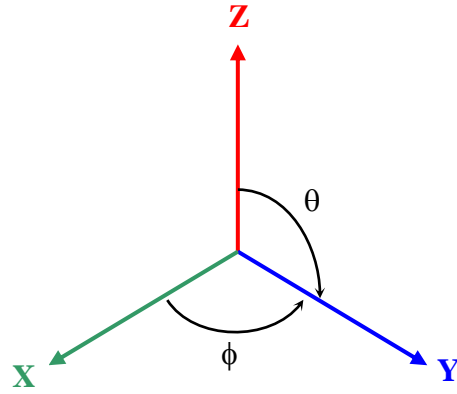
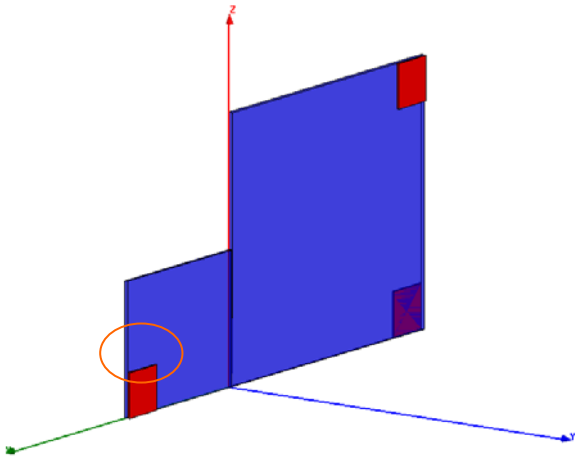

2450 MHz

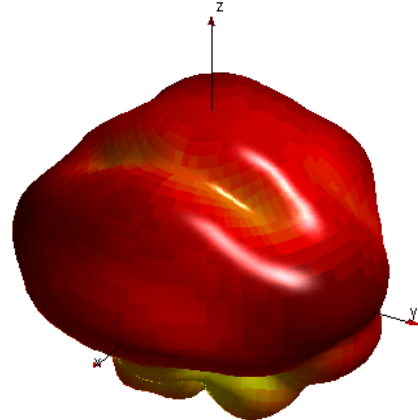
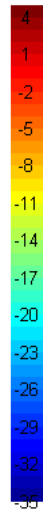

5400 MHz



Antenna 2

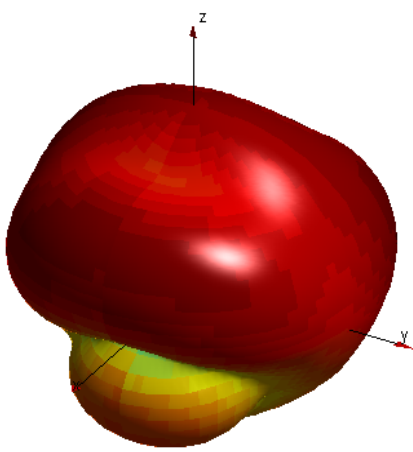
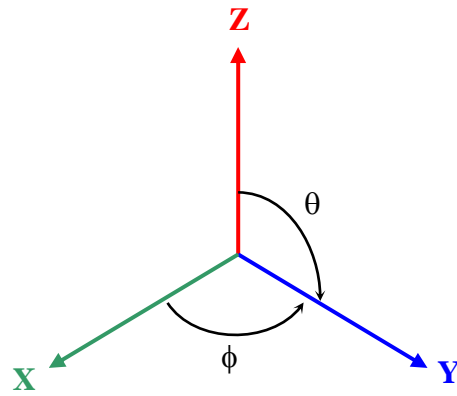
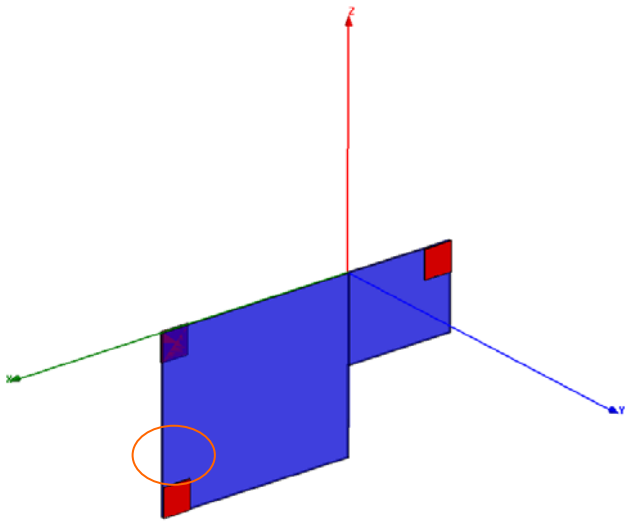

2450 MHz

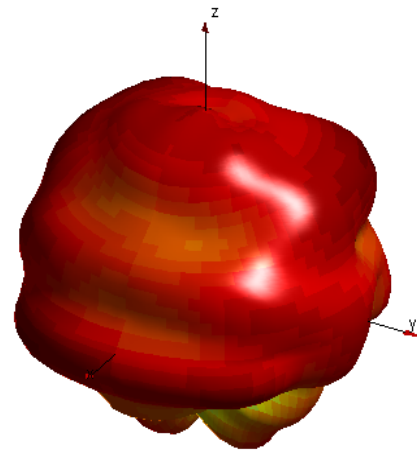
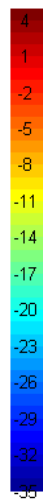

5400 MHz

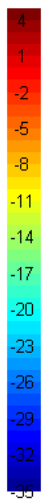

Antenna 3

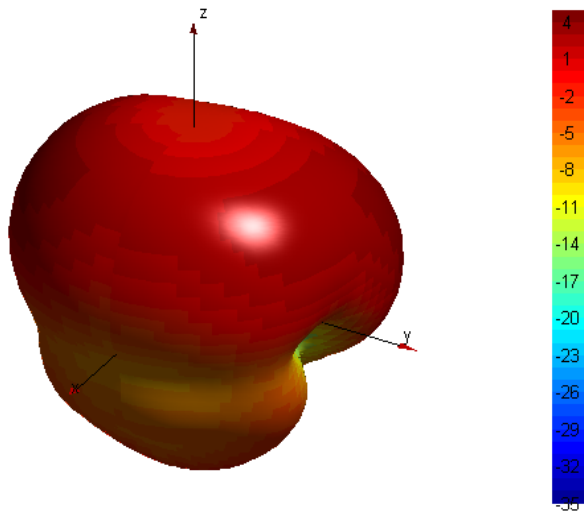
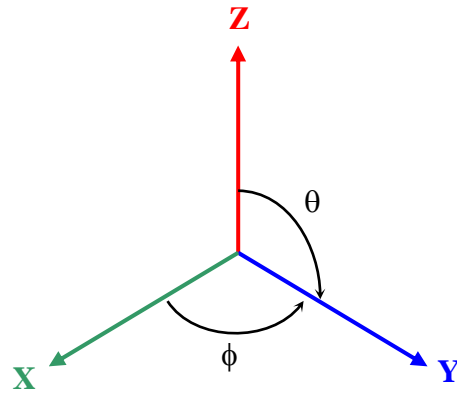
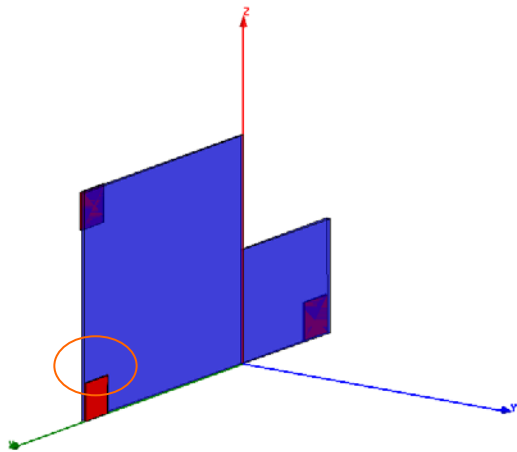

2450 MHz

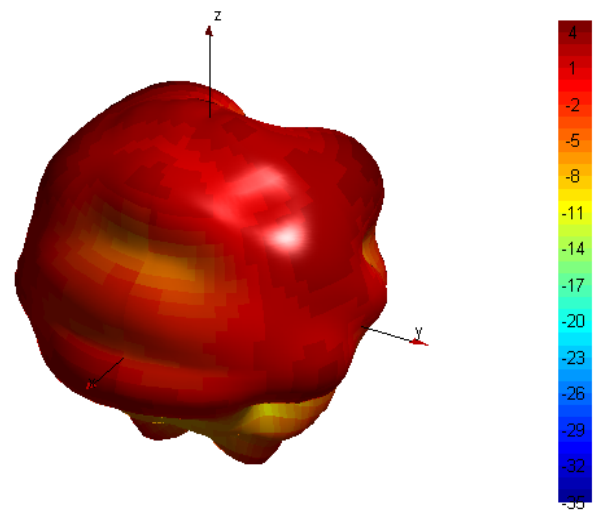

5400 MHz

Set-up 2, free space

Antenna 1

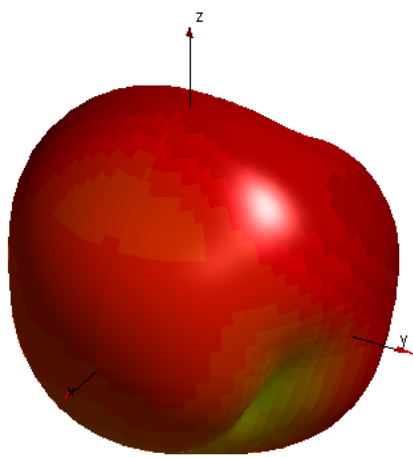
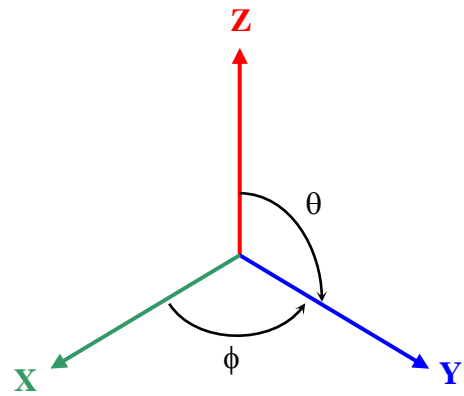
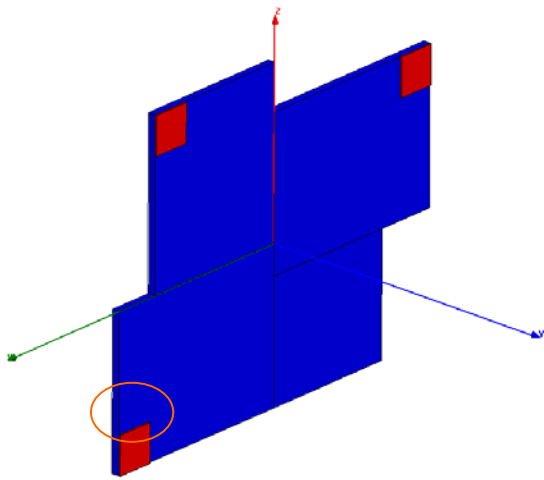

2450 MHz

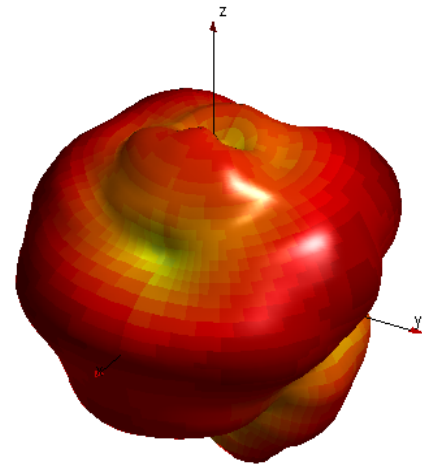
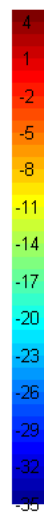

5400 MHz



Antenna 2

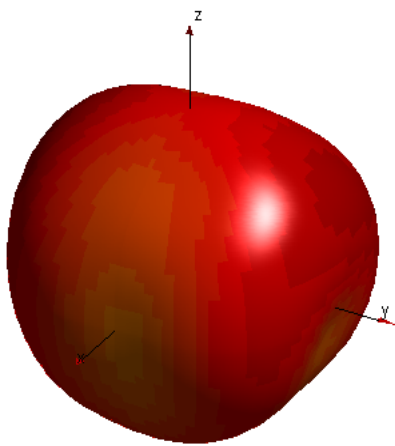
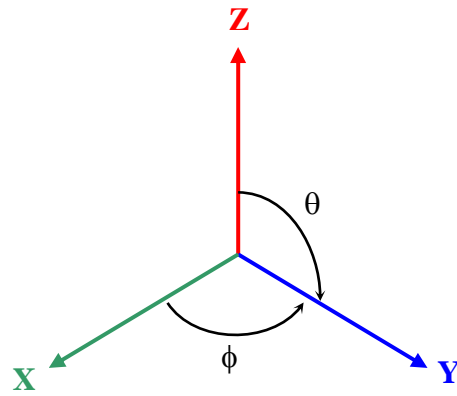
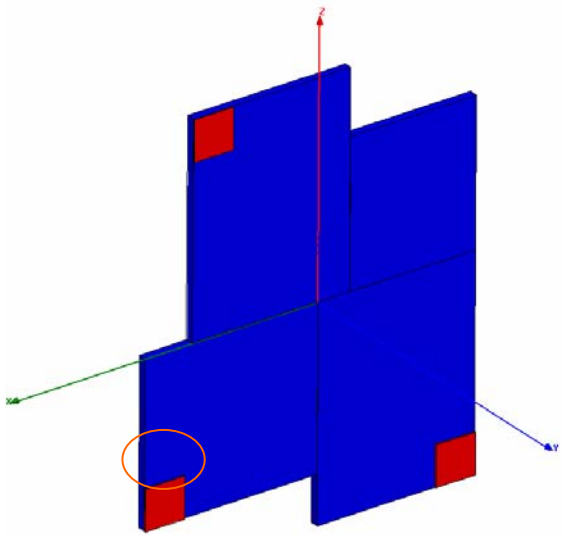

2450 MHz

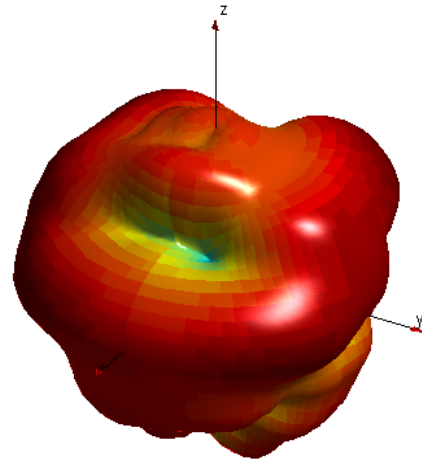
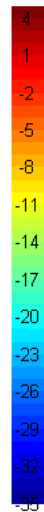

5400 MHz

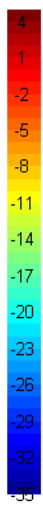

Antenna 3

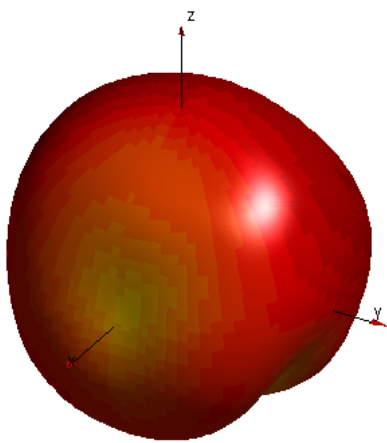
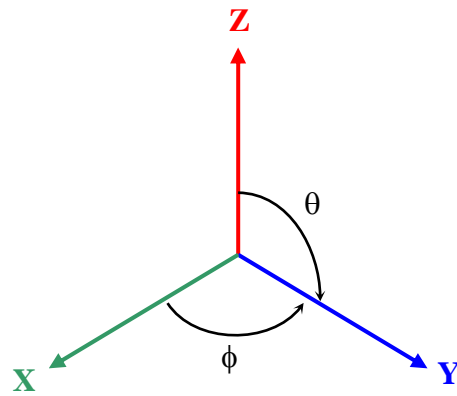
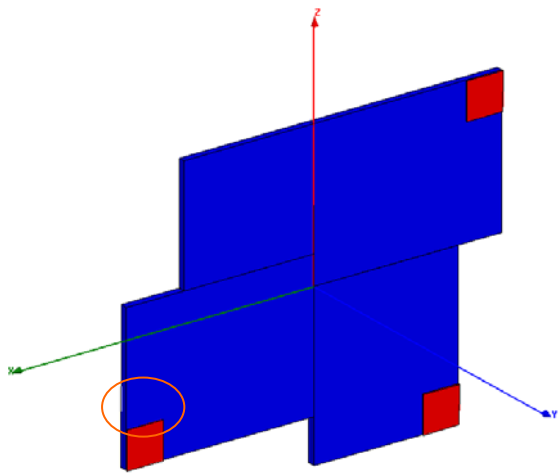

2450 MHz

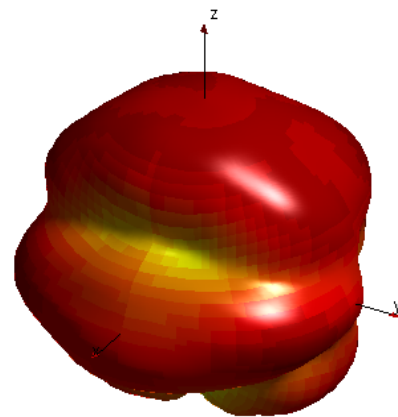
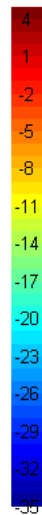

5400 MHz



Set-up 2b, metal sheet under PCB

Antenna 1

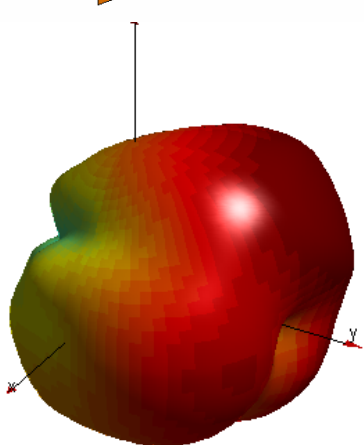
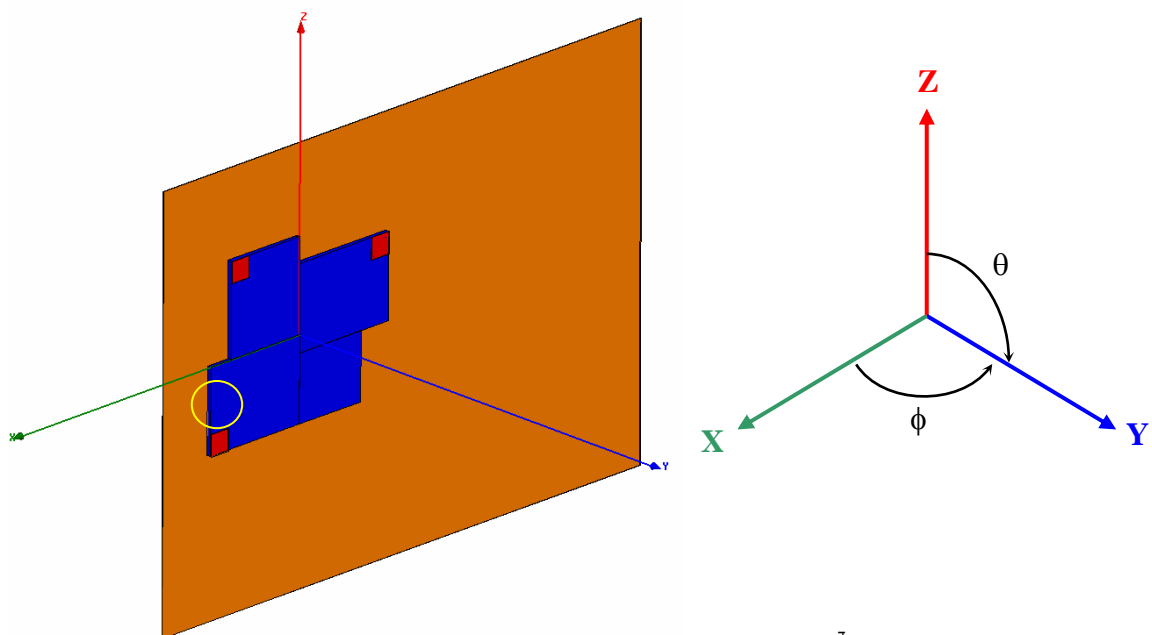

2450 MHz

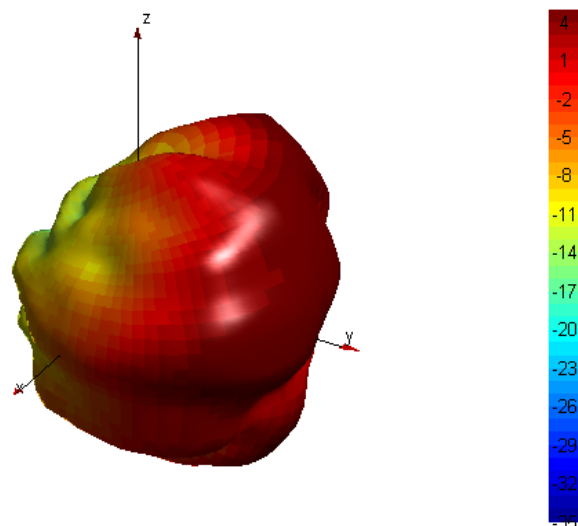

5400 MHz

Antenna 2

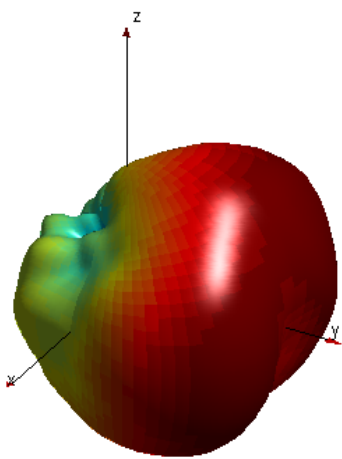
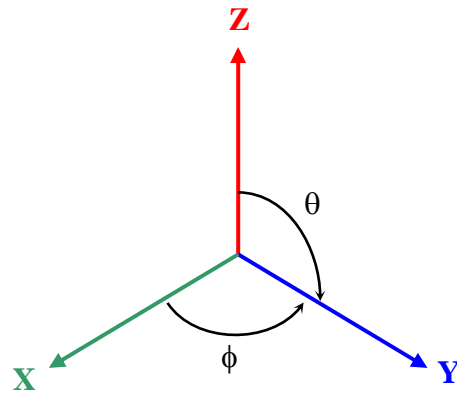
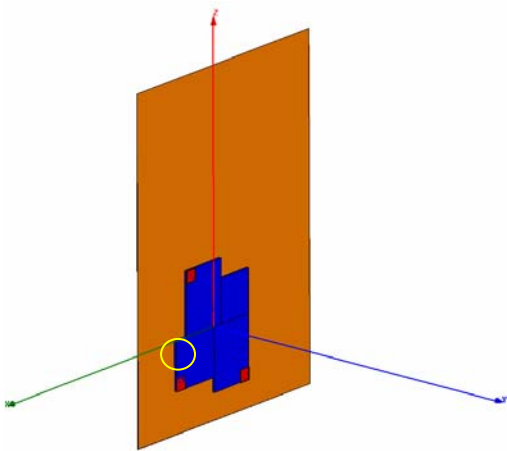

2450 MHz

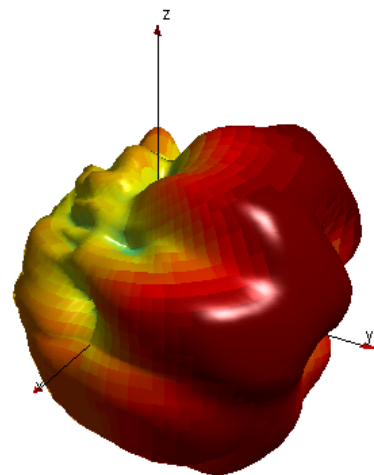

5400 MHz



Antenna 3

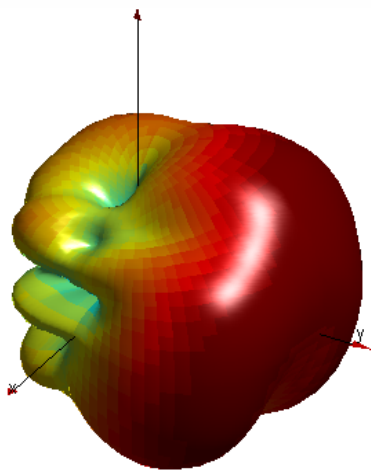
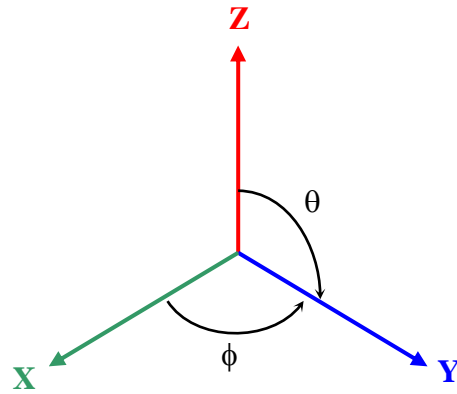
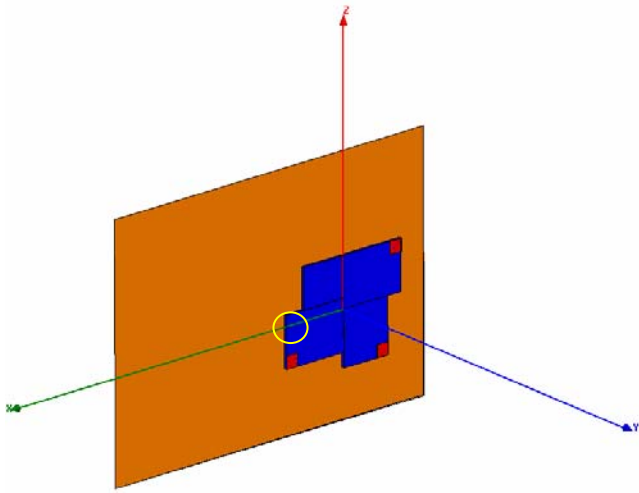

2450 MHz

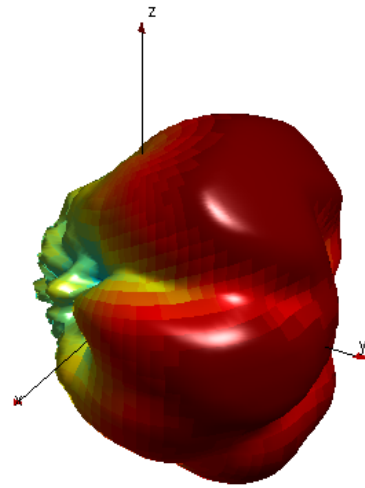
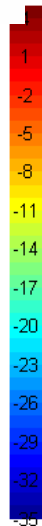

5400 MHz

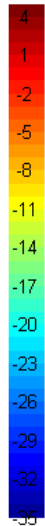



www.antenova.com

Corporate Headquarters

Antenova Ltd.
Far Field House
Albert Road
Stow-cum-Quy
Cambridge
CB25 9AR

Tel: +44 1223 810600
Fax: +44 1223 810650
Email: info@antenova.com

North America Headquarters

Antenova Ltd.
Rogers Business Park
2541 Technology Drive Suite 403
Elgin, IL 60124

Tel: +1 (847) 551 9710
Fax: +1 (847) 551 9719
Email: info@antenova.com

Asia Headquarters

Antenova Asia Ltd.
4F, No. 324, Sec. 1, Nei-Hu Road
Nei-Hu District
Taipei 11493
Taiwan, ROC

Tel: +886 (0) 2 8797 8630
Fax: +886 (0) 2 8797 6890
Email: info@antenova.com

Copyright® 2009 Antenova Ltd. All Rights Reserved. Antenova® and gigaNOVA® are trademarks of Antenova Ltd. Any other names and/or trademarks belong to their respective companies.

The materials provided herein are believed to be reliable and correct at the time of print. Antenova does not warrant the accuracy or completeness of the information, text, graphics or other items contained within these information. Antenova further assumes no responsibility for the use of this information, and all such information shall be entirely at the user's risk.



Certificate No: 4598