

DATASHEET

M10578-A3

M10578-A3 • RADIONOVA®

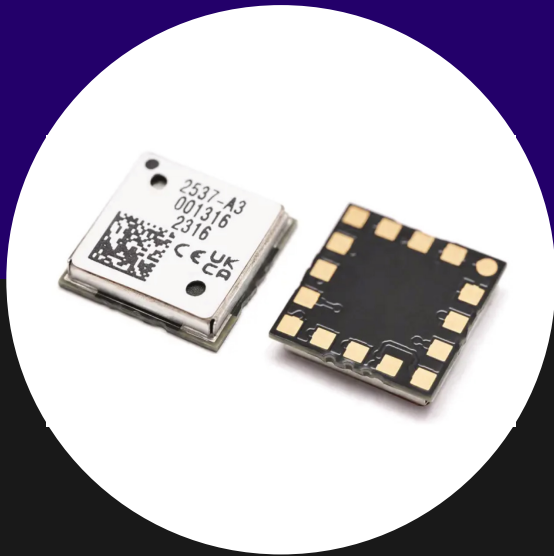

Features

- Multi-constellation GNSS receiver (GPS/GLONASS/GALILEO/BEIDOU)
- Full function GNSS module
- MediaTek MT3333 flash chip
- Ultra-small SMD package; 9.0 x 9.0 x 1.8mm
- Low current consumption
- AIC, Active Interference Cancellation
- EASY - Internally generated orbit prediction for fast fix times
- EPO (Extended Prediction Orbit) fast fix

1. Description

An integrated GNSS receiver module incorporating the MediaTek MT3333 flash chip. The receiver tracks 3 GNSS constellations concurrently (GPS+Galileo+GLONASS or GPS+Beidou). The receiver has configurable low power modes and operates from a 2.8V-4.2V supply. A 0.5ppm TXCO helps to speed up TTFF (Time to first fix). Multi-path algorithms improve position accuracy in inner-city environments. The on-board LNA provides good performance in weak-signal environments such as wearable devices.

2. Applications

- Wearable devices such as Fitness watches
- Portable devices
- Asset tracking / Personal safety
- Vehicle trip recording cameras
- Sports electronics such as Golf computers
- Navigation systems

3. Part number

M10578-A3

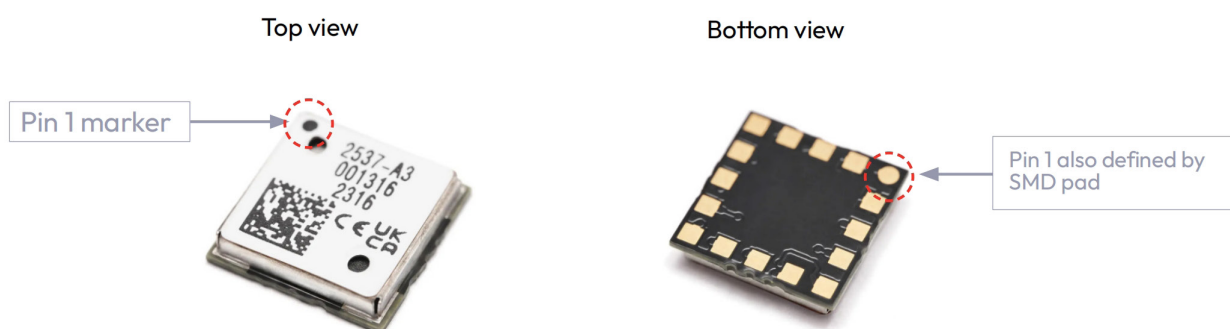

4. Functional block diagram

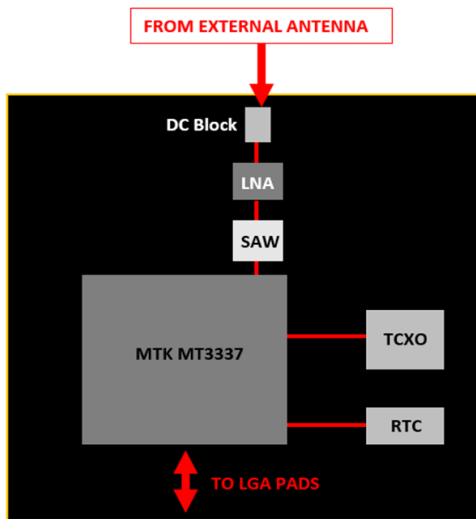

5. Module specifications

5.1. Absolute maximum ratings

SYMBOL	PARAMETER	MIN	MAX	UNIT
V_{CC}	Main supply voltage	-0.3	4.3	V
V_{IO}	Supply voltage I/O ring	-0.3	3.6	V
V_{BCKUP}	Backup supply voltage	-0.3	4.3	V
RF_{IN}	Maximum RF input power	N/A	+10	dBm
T_{STG}	Storage temperature	-40	+85	°C
T_{OP}	Operating temperature	-40	+85	°C

Exposure to absolute ratings may adversely affect reliability and may cause permanent damage.

5.2. Recommended operating conditions

SYMBOL	PARAMETER	MIN	TYP	MAX	UNIT
V_{CC}	Main supply voltage	2.8	3.3	4.3	V
V_{BCKUP}	Backup supply voltage	2.8	3.3	4.3	V
T_{OP}	Operating temperature	-40	-	+85	°C

5.3. DC electrical characteristics

Conditions: $V_{CC} = 3.3V$, $T_{OP} = 25\text{ }^{\circ}C$

SYMBOL	PARAMETER	TYP	UNIT
$I_{CC(ACQ)}$	Acquisition mode current	33	mA
$I_{CC(TRK)}$	Tracking mode current	28.5	mA
$I_{CC(STBY)}$	Standby (sleep) mode current	<500	μA
$I_{CC(BCKUP)}$	Backup mode current	<30	μA

5.4. RF specifications

Conditions: $V_{CC} = 3.3V$, $T_{OP} = 25\text{ }^{\circ}C$, Freq = 1575.420MHz

SYMBOL	PARAMETER	TYP	UNIT
NF_{LNA}	LNA Noise Figure (MT3337 Integral LNA)	2	dB
NF_{LNA1st}	1 st Stage LNA	0.65	dB

5.5. Band rejection

FREQUENCY	STANDARD	TYP*	UNIT
698-798	LTE700	49	dB
824-849	Cellular CDMA	49	dB
869-894	GSM850	49	dB
880-915	GSM900	49	dB
1710-1785	GSM1800/DCS	45	dB
1850-1910	GSM1900/PCS	43	dB
1920-1980	WCDMA	43	dB
2400-2492	WLAN, BT and WiMAX	43	dB
2500-2690	LTE2600	43	dB

Note: Does not include antenna rejection.

5.6. Mechanical specifications

PARAMETER	TYP	UNIT
Module exterior dimensions (L x W x H)	9.0 (±0.1) x 9.0 (±0.1) x 1.8 (+0.2 / - 0.0)	mm
Module support and connection	Surface mounted (SMD)	-
Module mass	≤0.35	g

5.7. System specifications

COMMUNICATION	SPECIFICATION
Data Output Protocol	NMEA 0183
Host Interfaces	UART
Default data rate on UART	9600 default rate, modify by input command
GPS ENGINE	
Chip	MTK MT3337-E ROM Chip
Channels	210 PRN / 66 Acquisition / 22 Tracking
TCXO	0.5ppm
ACCURACY	
Horizontal position accuracy	<2.5m CEP
Maximum position update rate	1 Hz (Default 1Hz)
SENSITIVITY	
Acquisition (Cold)	-148dBm
Acquisition (Hot)	-163dBm
Tracking	-165dBm
TTFF	
Hot start	<1s
Warm start	<25s (typical)
Cold start	<35s (typical)
GENERAL	
Maximum altitude	<18 km
Maximum speed	<514 m/s
Active interference cancellers	12 multi tone active cancellers; ISSCC2011 award
Additional features	1PPS Sync
EPO / EASY	Orbit prediction

50% CEP, Open-Sky, 24hr Static, -130dBm, good view of the sky

6. Module dimension

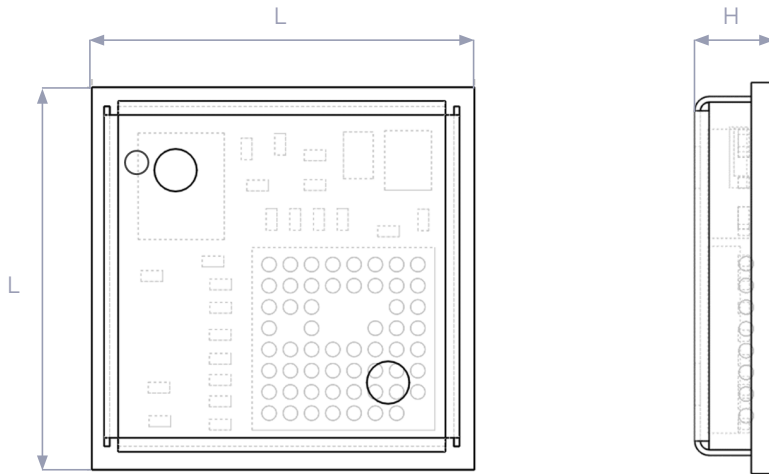

L	H
Length	Height
9.0 ±0.1	1.8 ±0.2 / -0.0

All dimensions in (mm)

7. Schematic symbol and pin definition

PIN	DESIGNATOR	DESCRIPTION
1	GND	Ground connection (Round pad)
2	GND	Ground connection
3	RF_IN	RF connection from antenna (50Ω)
4	GND	Ground connection
5	GND	Ground connection
6	1PPS	Pulse per second output
7	HW_R	System reset, active low
8	HW_S	Used to enable standby mode; If not used leave floating
9	RX	UART Receive data line
10	TX	UART Transmit data line
11	E2	Hardware baud rate select
12	E3	Hardware baud rate select
13	FIX	Indicates once a GPS fix has been obtained
14	BV	Backup supply voltage, +3.3V in TYP
15	VCC	Main supply voltage, +3.3V in TYP
16	GND	Ground connection

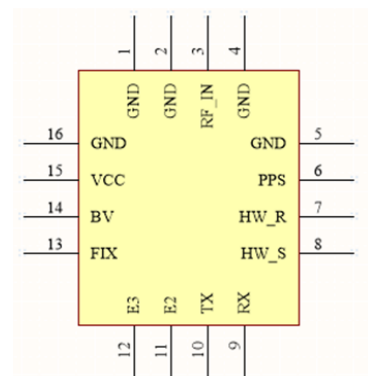

8. Host PCB footprint

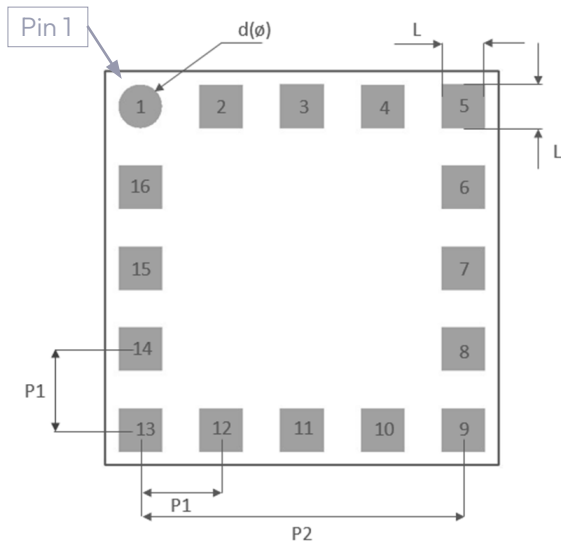

L	P1	P2	D(∅)
Pad Size	Pad pitch	Pitch total	Diameter pad 1
1.0	1.85	7.40	1.0

All dimensions in (mm)

9. Module subsystem feature

9.1. Host baud rate/protocol selection

The baud rate and output protocol can be changed dynamically after start-up using the relevant commands. Please contact Antenova for more information about protocol messages.

9.2. Host interface

The UART converts bytes of data to and from asynchronous start-stop bit streams as binary electrical impulses. The port contains a 16-byte FIFO, and 256 bytes of URAM. The baud rates are selectable from 4800, 9600, 38400 and 115200 bps.

The IO level from the UART port are CMOS compatible, however for RS232 compatibility the use of external level shifters will be required. The hardware configuration of the port baud rate can be changed dynamically by the use of commands. These will be active and saved as long as the BV supply is applied.

9.3. Power supply

The M10578-A3 uses two DC supply inputs. BV to power the RAM and RTC sections of the receiver, and VCC to power the digital and processing sections. BV is to be applied all the time to keep these sections on. VCC can be removed to initiate a backup power save mode (See page 9). BV can be supplied with a battery. The supply is internally regulated for 2.8V meaning the external supply is versatile for a range of voltage levels.

9.4. TM (1PPS)

TM is a 1PPS (pulse per second) output from the receiver providing an accurate synchronized output. The pulse width is 100ms. Enable this function using PMTK255 (Default off)

9.5. HRST (Hardware reset pin)

The External reset pin is default high by an internal 75Kohm and should be left floating if not used. To initiate a reset the pin needs to be pulled low. The module also initiates a reset if the VCC drops below the minimum 2.8V supply

9.6. Power management

The M10578-A3 has three power saving modes.

- Standby mode
- Back up mode
- Periodic mode

9.6.1. Standby mode

Standby mode is a power saving mode that shuts down the RF section of the module and puts the processor into a standby mode. The RTC is kept alive, and the RAM power is maintained to keep the module configuration.

The standby state can be initiated either with a hardware signal to Pin8 or by using a command.

Hardware controlled Standby: Enable standby mode by a low state to Pin8 (HW_S). To wake the module back to full power a high state needs to be applied to Pin8. If Pin8 is not to be used, then it must be kept floating (not connected).

Standby mode command: Software on the host needs to send the "PMTK161" command through the UART interface.

Command M10578-A3 standby then

COMMAND	M10578-A2 STANDBY THEN WAKEUP	CURRENT CONSUMPTION (TYP)
\$PMTK161,0*28	M10578-A2 enters standby mode	<500uA
Any byte	M10578-A2 wakes up from standby mode	

9.6.2. Backup mode

To enter backup mode the VCC simply needs to be removed. Once initiated the RTC and all configuration is saved along with any ephemeris data to allow quick TTFB once the VCC is re-applied. BV needs to be applied at all times for backup mode to run correctly.

9.6.3. Periodic mode

Periodic mode is a module controlled mode that reduces current consumption by only waking the module for short periods to maintain fix data. The periodic state is user configured. Contact Antenova for more information and a user command manual.

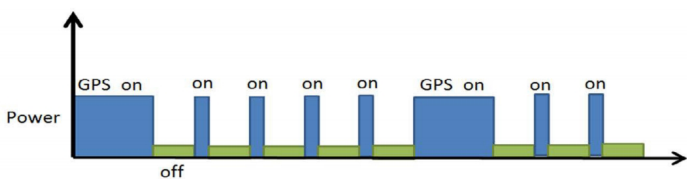

Command (Example)	M10578-A3 time off/awake
\$PMTK225, 1,3000, 12000, 18000, 72000	Module sleep 12s then run 3s in signal condition; Module sleep 72s then run 18s in no signal condition.

9.7. EPO (Extended Prediction Orbit) data service

The EPO allows the use of up to 30-day orbit predictions that can be used to aid the module for an instant fix solution.

- A proxy server on the customer’s side to update EPO files from the MTK server daily.
- Application software to access the proxy server through the internet (optional if host device can access internet).
- Software on host device to send EPO data to M10578-A3 module to allow instant fix by using EE data. Please contact Antenova for more information. Requires permission from MTK to use service.

9.8. EASY (Self-Generated Orbit Prediction)

The module supports EASY™ (Embedded Assisted System) is a Self-Generated

Orbit Prediction feature. It provides up to 3 days GPS orbit prediction ability without the need for any host CPU porting or internet connection requirements.

EASY works as embedded software which accelerates TTFF by predicting satellite navigation messages from received ephemeris. EASY is a fully automated receiver task that is efficiently scheduled and computed in free time of every second after a GNSS navigation solution.

EASY is default off and can be enabled by a PMTK command.

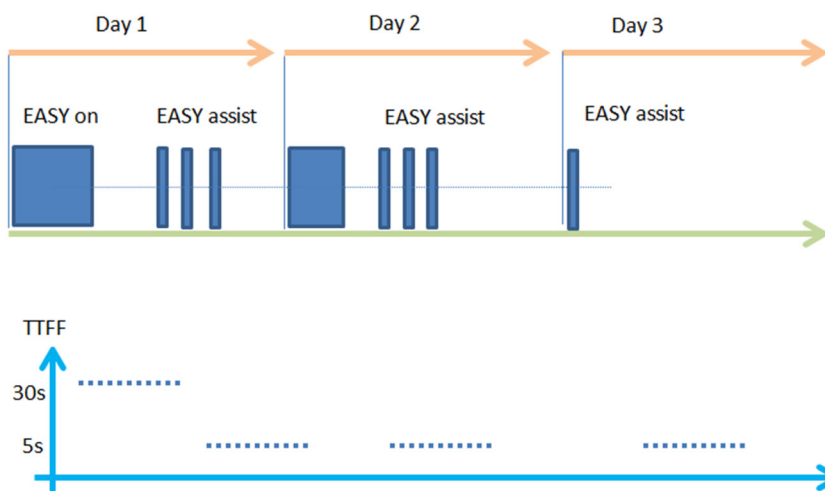

9.9. AIC (Active Interference Cancellation)

The AIC feature provides effective narrow-band interference cancellation. The GPS signal can be recovered from signals that contain interference signals. High speed processors generate clock harmonics that cause interference to be present within the GPS band.

10. Module application

The circuit below shows a basic design for use with the UART interface and configuring the default baud rate to 9600.

Baud Rate = 9600 (Default)

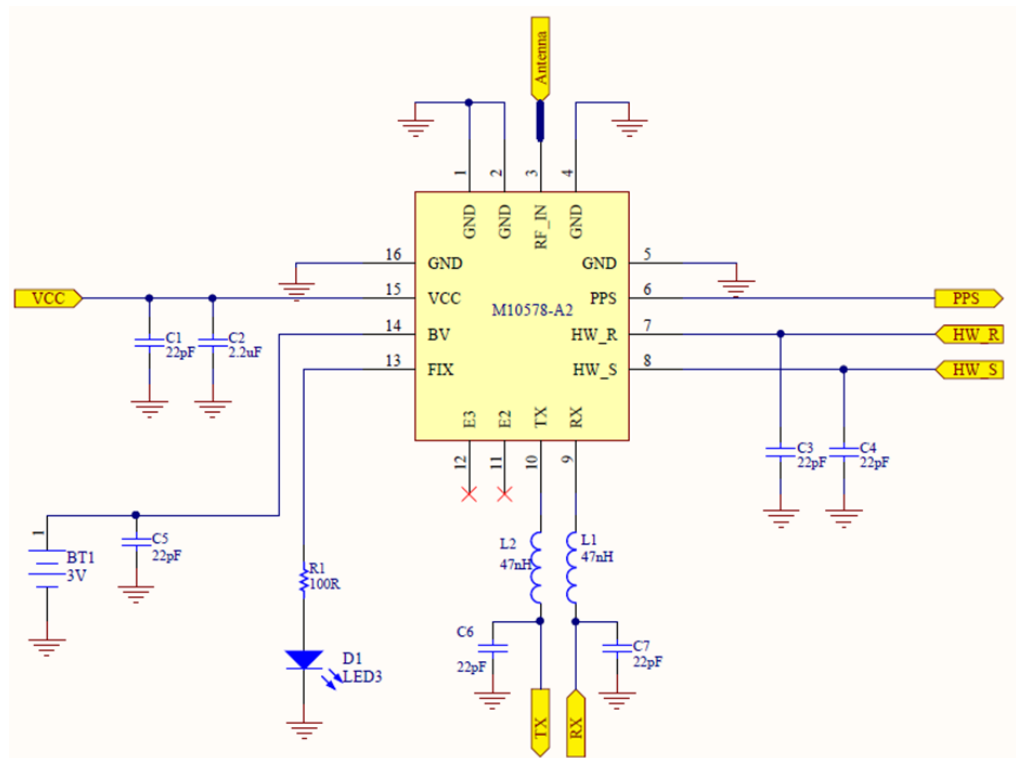

Bill of Material

DESIGNATOR	VALUE	DESCRIPTION/COMMENTS	QUANTITY
C1, C3, C4, C5, C6, C7	22pF capacitor	Decoupling cap. Place close to corresponding pin	6
C2	2.2μF capacitor	Decoupling cap. Place close to corresponding pin	1
L1, L2	47nH Inductor	Filter component	2
BT1	3V Battery	3.0Volt battery cell for battery backup	1
D1	LED	Illuminates when GPS fix	1
R1	0 ohm	For LED drive	1

11. Evaluation kit

The EVK is a single PCB that contains the M10578-A3 module and required components to run on a PC via a USB cable and Antenova software. Evaluation kits are available on request. Please contact Antenova for more information. (Part number: M10578-A3-U2).

To order a reference board please see antenova.com

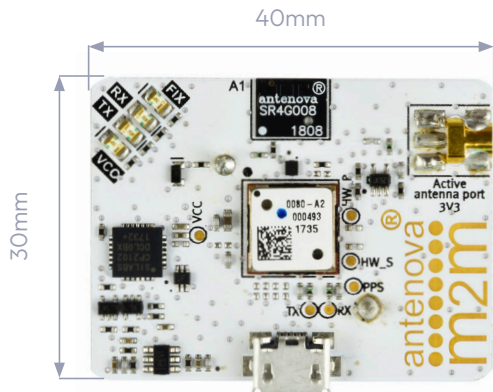

Front view

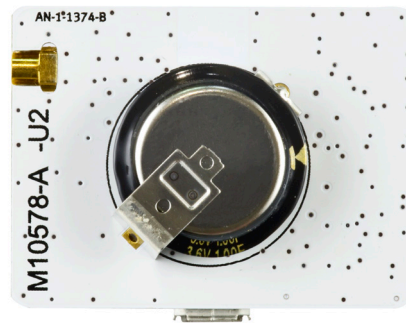

Bottom view

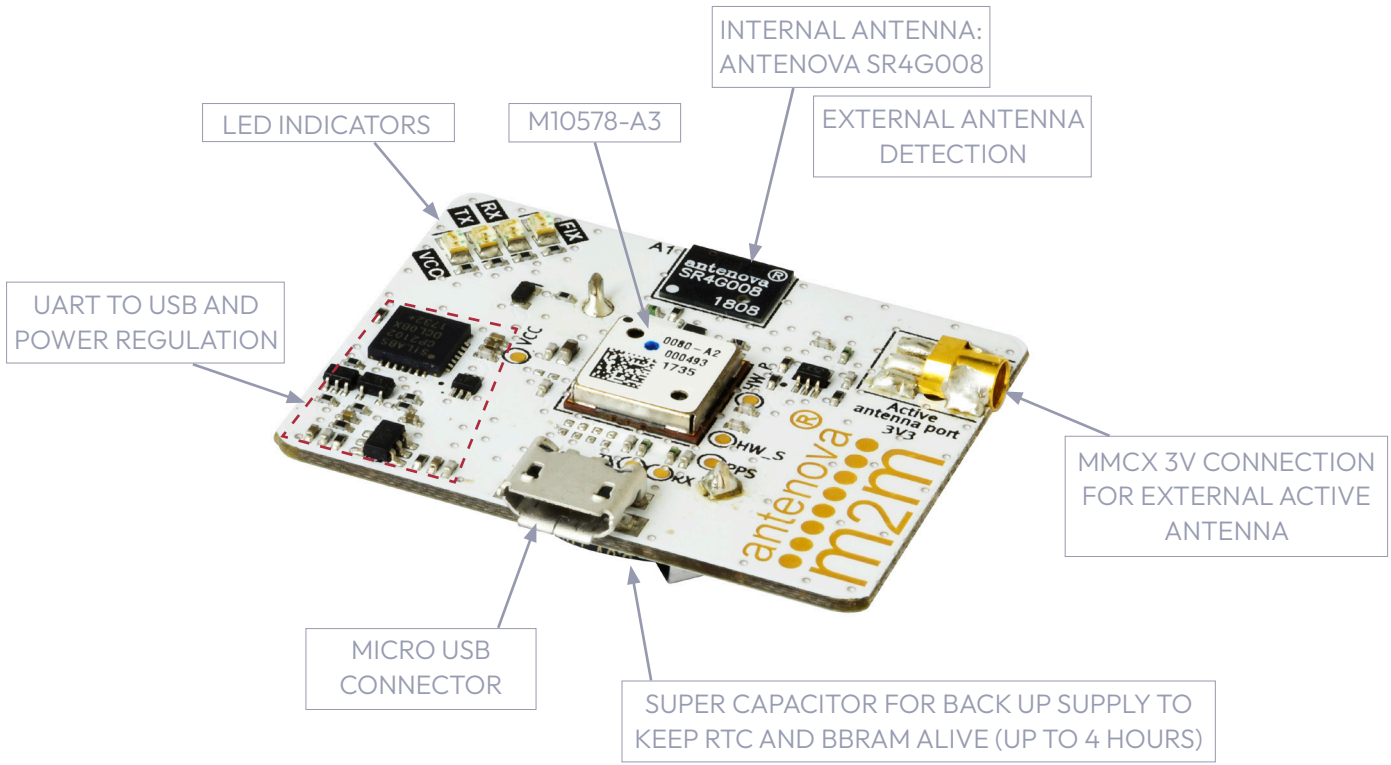

12. Reflow soldering

12.1. Placement

Typical placement systems used for any BGA/LGA package are acceptable.
 Recommended nozzle diameter for placement: 5mm

12.2. Soldering paste

Use of “No Clean” soldering paste is strongly recommended, as it does not require cleaning after the soldering process has taken place. An example of suitable soldering paste is Alpha OM350.

12.3. Soldering

The recommended soldering profile for M10578-A3 is shown below. However, it is the responsibility of the Contract Manufacturer to determine the exact reflow profile used, taking into consideration the parameters of the host PCB, solder paste used, etc.

PROFILE FEATURE		PB-FREE SOLDER
Pre-Heat	Temperature (T_s) Min	130°C
	Temperature (T_s) Max	220°C
	Time (t_s)	<150s
Reflow	Liquidus Temperature - (T_l)	220°C
	Time (t_l)	45-90s
Peak Package Body Temperature (T_p)		245°C
Time within 5°C of peak temp (t_p)		30s
Average Ramp up rate - T_s (max) to (T_p)		3°C/s
Ramp Down Rate		6°C/s max

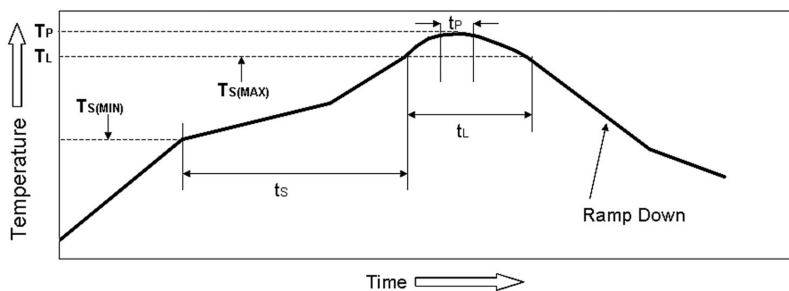

The Pb Free Process-Package Peak Reflow Temperature is 260°C.
 Exceeding the maximum soldering temperature could permanently damage the module.

12.4. Multiple soldering

The M10578-A3 module can be submitted up to 2 reflow soldering processes.

Upside-down soldering is acceptable but it is recommended that the Contract Manufacturer qualify the process before mass production. The second reflow must take place within the recommended floor life limit (MSL3). Please contact Antenova for further information

12.5. Hand soldering

Hand-soldering and rework of the M10578-A3 module is acceptable, however care must be taken to avoid short circuits due to the small size of the module pads

13. Quality and environmental specifications

TEST	STANDARD	PARAMETERS
PCB inspection	IPC-6012B, Class 2. Qualification and Performance Specification for Rigid Printed Boards - Jan 2007	
Assembly inspection	IPC-A-610-D, Class 2 "Acceptability of electronic assemblies"	
Temperature range	ISO16750-3	-30 °C, +25 °C, +85 °C, operating
Moisture/Reflow sensitivity	IPC/JEDEC J-STD-020D.1	MSL3
Storage (Dry Pack)	IPC/JEDEC J-STD-033C	MSL3
Solderability	EN/IEC 60068-2-58 Test Td	More than 90% of the electrode should be covered by solder. Solder temperature 245 °C

Moisture sensitivity:

Antenova ships all devices dry packed in tape on reel with desiccant and moisture level indicator sealed in an airtight package. If on receiving the goods the moisture indicator is pink in colour or a puncture of the airtight seal packaging is observed, then follow J-STD-033 "Handling and Use of Moisture/Reflow Sensitive Surface Mount Devices".

14. Hazardous material regulation conformance

The RF antenna module has been tested to conform to RoHS and REACH requirements. A certificate of conformance is available from Antenova's website.

15. Packaging

15.1. Optimal storage conditions

TEMPERATURE	-10°C to 40°C
HUMIDITY	Less than 75% RH
SHELF LIFE	24 Months
STORAGE PLACE	Away from corrosive gas and direct sunlight
PACKAGING	Reels should be stored in unopened sealed manufacturer's plastic packaging.
MSL LEVEL	3

Note:

The M10578-A3 modules meet MSL Level 3 of the JEDEC specification J-STD-020D - 168 hours Floor Life (out of bag) ≤ 30 °C/60% RH. If the stated floor life expires prior to reflow process then follow J-STD-033 "Handling and Use of Moisture/Reflow Sensitive Surface Mount Devices".

The shelf life of the antenna is 2 years provided the factory seal on the package has not been broken.

15.2. Tape characteristics

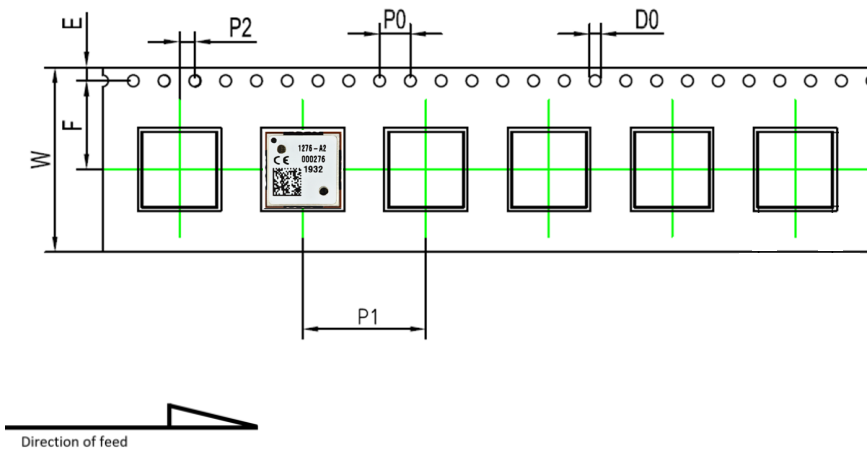

P0	P1	P2	D0
4.00 ± 0.1	16.00 ± 0.1	2.00 ± 0.1	1.55 ± 0.1

E	F	W
1.75 ± 0.1	11.50 ± 0.1	24.00 ± 0.3

All dimensions in (mm)

QUANTITY	LEADING SPACE	TRAILING SPACE
1000 pcs / reel	50 blank module holders	50 blank module holders

15.3. Reel dimensions

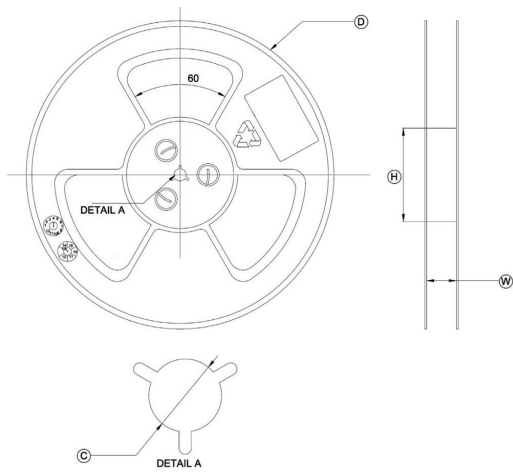

D	C	H	W
330.0 ± 2.0	13.3 ± 0.3	100.0 ± 3.0	24.5 ± 0.2

All dimensions in (mm)

15.4. Box dimensions

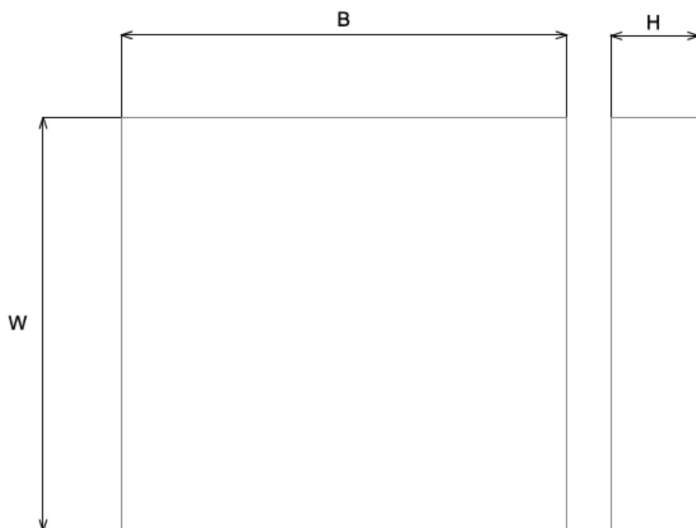

Width (W)	Breadth (B)	Height (H)
340mm	339mm	53mm

15.5. Bag properties

Reels are supplied in protective plastic packaging.

15.6. Reel label information

Antenova Limited **antenova**
www.antenova.com

DESCRIPTION: GPS MODULE 
PART NUMBER: M10578-A3 
QTY: 1,000 pcs 
DATE CODE: YYWW 

  GNSSNOVA®

Quality statements

Antenova's products conform to REACH, RoHS legislation, and CE certification. For our statements regarding these and other quality standards, please download from [Antenova resources page \(https://blog.antenova.com/topic/qa-docs-certificates\)](https://blog.antenova.com/topic/qa-docs-certificates)



Antenova reserves all rights to the contents of this document. Antenova gives no warranties based solely on the accuracy or completeness of the contents of this document and reserves the right to make changes to the specifications of the products described herein at any time and without notice.

Datasheet version

4.01 release 21st April 2026

Antenna design, integration and test resources

Product designers – the details contained in this datasheet will help you to complete your embedded antenna design. Please follow our technical advice carefully to obtain optimum antenna performance.

We aim to support our customers to create high performance wireless products. You will find a wealth of design resources, calculators and case studies to aid your design on our website.

Antenova's design laboratories are equipped with the latest antenna design tools and test chambers. We provide antenna design, test and technical integration services to help you complete your design and obtain the required certifications.

If you cannot find the antenna you require in our product range, please contact us to discuss creating a custom antenna to meet your exact requirements.

Share knowledge with RF Experts around the world

ask.antenova is a global forum for
designers and engineers working with
wireless technology

[Visit Ask.Antenova](#)

Visit antenova.com

**Order antenna samples and
evaluation boards, and read our
antenna resources**

[Visit antenova.com](#)

Request a volume quotation for antennas:

[**sales@antenova.com**](mailto:sales@antenova.com)

+ 44 (0) 23 9400 1023

Global headquarters

**Antenova Ltd, 7 The Briars,
Waterberry Drive, Waterlooville,
Hampshire, PO7 7YH**